

Two-fiber Detachable DVI Module



Description

The Digital Visual Interface is a high-quality, uncompressed data link between a host processor video card and a display peripheral. Optical technology for this transmission stretches the performance beyond the limitations of copper wire with longer length, data security, negligible RFI/EMI and the elimination of costly analog distribution systems.

The EDID in a display can be read and restored by just plugging it to the display. This self EDID programming feature makes the installation of M1-201DA-TR more easy and flexible at any variable resolution display systems.

The four (4) optical data, Red, Green, Blue and clock are multiplexed and de-multiplexed through CWDM optical module. Graphic data can be extended up to 1,500 meters (4,920ft) at WUXGA resolution (1900x1200) of 60Hz vertical refresh rate over two (2) LC fibers.

An external power adapter is required for the receiver module, while most video cards can provide +5V DC power to the transmitter module. The transmitter and receiver modules are clearly labeled to prevent reverse installation of the modules.

Key Features

- Extends all VESA resolution up to WUXGA (1,920x1,200) 60Hz DVI data up to 1,500 meters (4,920 feet).
- Applicable to both single and multi-mode fibers.
 - (1) Up to 1,500m with two LC single-mode fibers.
 - (2) Up to 500m with two LC multi-mode fibers.
- Offers self-EDID programming feature, detecting from a display and restoring to an EEPROM in the transmitter just by plugging to the display without any physical DDC connection.
- The modules are compact enough to directly plug to graphic sources and displays by adopting DVI-plugs.
- Includes two (2) +5V DC power adapters for the transmitter and receiver.
- Certifies FCC and CE standards for EMI/RFI emission.
- Data security with negligible RFI/EMI emissions and loss of video quality due to no copper conductor present.

Applications

- Digital FPD, PDP and projector installation in conference rooms, auditoriums and for kiosk systems.
- Digital display system integration for medical, military, aerospace, factory automation, and traffic control platforms.
- LED signboards for large scale information display and stadiums.
- Home Theatre Systems.

Detachable DVI Extension Module (M1-201DA-TR)

Optical Fiber Connection

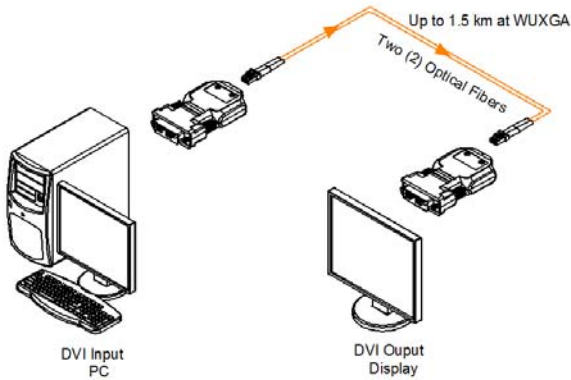

Drawings

(Unit : mm)

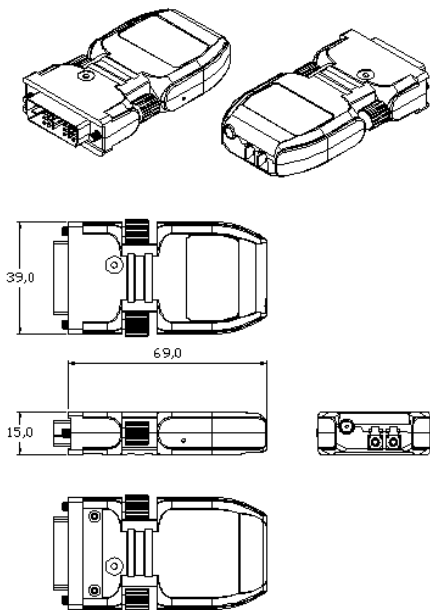

Note: The transmitter, M1-201DA-Tx and the receiver, M1-201DA-Rx have the same mechanical dimensions.

Electrical Power Supply Characteristics

Transmitter Specifications						
	Parameters	Symbol	Min.	Typ.	Max.	Units
Power Supply	Supply Voltage	V _{CC}	4.5	5.0	5.5	V
	Supply Current	I _{TCC}	350	400	570	mA
	Power Dissipation	P _{TX}	1.75	2.0	2.85	W
	Power Supply Rejection	PSR		50		mV _{p-p}
TMDS	Data Output Load	R _{LD}		50		Ω
	Graphic Supply Voltage	GV _{CC}	+ 3.1	+ 3.3	+ 3.5	V
	Single-Ended Input Swing Voltage	GV _{ISWING}	0.4	-	0.6	V
Optical Link	Output Optical Power	P _o	-10.0		-3.0	dBm
	Wavelength	λ _{c1}	1260	1310	1360	nm
		λ _{c2}	1480	1550	1580	
	Extinction Ratio	Ext	4	5		dB
	Rising/Falling Time	T _{rise} /T _{fall}			260	ps
Jitter in p-p value	T _{jitter}			270	ps	
Receiver Specifications						
	Parameters	Symbol	Min.	Typ.	Max.	Units
Power Supply	Supply Voltage	V _{CC}	4.5	5.0	5.5	V
	Supply Current	I _{RCC}	350	420	570	mA
	Power Dissipation	P _{RX}	1.75	2.1	2.85	W
	Power Supply Rejection	PSR		50		mV _{p-p}
TMDS	Data Input Load	R _{LD}		50		Ω
	Graphic Supply Voltage	GV _{CC}	+ 3.1	+ 3.3	+ 3.5	V
	Single-Ended Output Swing Voltage	GV _{ISWING}	0.2	-	0.4	V
Optical Link	Receiving Optical Power	P _o	-20		-3.6	dBm
	Receiving Wavelength	λ _{c1}	1260	1310	1360	nm
		λ _{c2}	1480	1550	1580	
	Signal Detect Good	SDg			-17	dBm
	Signal Detect Fail	SDf	-25			dBm
Link Power Budget	P _{bgt}	7	10		dB	
Total Jitter	TR _{jitter}			309	ps	

Recommended Operating Conditions

Parameter	Symbol	Min	Typ	Max	Units
Ambient Operating Temp.	T _A	0	25	+ 50	°C
Storage Temperature	T _s	-10		+85	°C
Storage Humidity	H _s	5		85	RH%

Headquarters

Opticis Co., Ltd.
304, Byucksan Technopia, 434-6
Sangdaewon-Dong, Chungwon-Ku,
Sungnam-Si, Kyungki-Do, 462-716
South Korea
Tel : +82 (31) 737-8033~8
Fax: +82 (31) 707-8079

www.opticis.com
tosales@opticis.com

North American Office

Opticis USA LLC
649 Route 206
Unit 9 Suite 307
Hillsborough, NJ 08844 USA
Tel : +1 (908) 837-9652
Fax: +1 (908) 837-9078

cdkim@opticis.com