

DATA SHEET

DVI - HDCP Extension Cable

M1-1000-xx

Contents

- ◆ Description
- ◆ Features
- ◆ Absolute Maximum Ratings
- ◆ Recommended Operating Conditions
- ◆ Electrical Power Supply Characteristics
- ◆ Receiver Electrical Interface
- ◆ Specifications of fiber-optic cables
- ◆ Drawing of transmitter and receiver modules
- ◆ DVI Pin Description
- ◆ Reliability Test of Modules
- ◆ Terminology

Headquarters

Opticis Co., Ltd
501, Byucksan Technopia
434-6 Sangdaewon-Dong, Chungwon-Ku
Sungnam City, Kyungki-Do, 462-120
South Korea
Tel: +82 (31) 737-8033
Fax: +82 (31) 707-8079
Email: sales@opticis.com
www.opticis.com

North American Office

Opticis North America, Inc.
330 Richmond Street, Suite 100,
Chatham, Ontario
CANADA N7M 1P7
Tel : (519) 355-0819
Fax : (519) 355-0520
Email : roger@opticis.com

Optical DVI - HDCP Extension Cable

*** Point-to-point optical fibre cable ***

Description

The reality of gigabit high-speed digital graphic interconnections mandates products that maintain front-of-screen video quality. Optical technology extends the ability to transmit digital graphic data beyond the physical limits of copper wires by, i) providing pure signal integrity over long distances for the optimum visual experience, ii) no EMI/RFI transmission or reception, iii) light weight, rugged cabling and connectors, iv) very cost effective per foot/metre, v) low power consumption, and vi) plug and go installation ease – no software requirements.

The M1-1000 consists of a transmitter and a receiver, connected by all fiber-optic distribution cables with male DVI-D connectors at each end. The Transmitter and Receiver modules are respectively implemented by Opticis designed and manufactured 850nm VCSEL and PIN-PD arrays.

The M1-1000 product makes DDC / HDCP interconnection over pure fibers as well as transmission of the Red, Green, Blue, and Clock TMDS graphic data over fibers. The cable can be any length up to 500m (326feet) for WUXGA (1,920x1,200) 60Hz data. An external power is required for the receiver module, while most video cards, at least 500mA of +5V voltage can provide DC power to the transmitter module.

The shipping group is as follows;

- 1) One DVI / HDCP cable: M1-1000-yyy, where y = length in metres.
- 2) Factory will stock “standard” lengths of 10m, 20m, 30m and 50m.
- 3) User Manual

Feature

- ◆ Supports all VESA resolutions up to WUXGA (1,920x1,200), at 60Hz refresh rate with 1 pixel/clock mode.
- ◆ Embeds pure fiber distribution cable with 8 strands Multimode Glass of fibers not only for the TMDS video interface and but also to support the DDC2B/HDCP, which offers perfect electrical isolation.
- ◆ Extends up to 500 meters (1,560 feet).
- ◆ Applicable of both powers from graphic cards and an external adaptor for the transmitter while powering the receiver from an external +5V adaptor.
- ◆ Compact end connector design easily allows direct connect to the host video card and display peripheral.
- ◆ No software to install; just plug and go.
- ◆ Data security with negligible RFI/EMI emissions

Applications

- ◆ Digital display system integration for medical, military, aerospace, factory automation, and traffic control platforms.
- ◆ Digital FPD, PDP and projector installation in conference rooms, auditoriums and for kiosk systems
- ◆ LED signboards for large scale information display and stadiums
- ◆ Home Theatre Systems

Absolute Maximum Ratings

Parameter	Symbol	Minimum	Maximum	Units
Storage Temperature	T_{stg}	- 30	+ 70	°C
Supply Voltage	V_{CC}	- 0.3	+ 6.0	V
Transmitter Differential Input Voltage	V_d	-	1	V
Relative Humidity	RH	10	85	%
Lead Soldering Temperature & Time	-	-	-	260°C, 10 sec

Recommended Operating Conditions

Parameter	Symbol	Minimum	Typical	Maximum	Units
Ambient Operating Temperature	T_A	0		+ 50	°C
Data Output Load	R_{LD}		50		Ω
Power Supply Rejection (Note1)	PSR		50		mV _{p-p}
Supply Voltage	V_{CC}	+ 4.5	+ 5.0	+ 5.5	V
Graphic Supply Voltage (Note2)	GV_{CC}	+ 3.0	+ 3.3	+ 3.6	V

Note1. Tested with a 50mV_{p-p} sinusoidal signal in the frequency range from 500 Hz to 500 MHz on the V_{CC} supply with the recommended power supply filter in place. Typically less than a 0.25 dB change in sensitivity is experienced.

Note2. Graphic Supply Voltage is only for the Graphic Signal Interface, which is generated by regulator in the Transmitter and Receiver

Electrical Power Supply Characteristics

($T_A = 0\text{ }^{\circ}\text{C}$ to $+50\text{ }^{\circ}\text{C}$, unless otherwise noted)

Parameter		Symbol	Minimum	Typical	Maximum	Units
Supply Voltage		V_{CC}	4.5	5	5.5	V
Supply Current	TX	I_{TCC}	-	180	200	mA
	RX	I_{RCC}	-	180	200	mA
Power Dissipation	TX	P_{TX}		0.9	1.1	W
	RX	P_{RX}	-	0.9	1.1	W

Specifications of Fibre-Optic Cables

Parameter	Value	Parameter	Value
Core Diameter	62.5 ± 3.0µm	Cladding Diameter	125 ± 2.0µm
Coating Diameter	245 ± 15µm	Outside Diameter	5.5 ± 0.2mm
Proof Test Level	> 100kpsi		

Drawing of transmitter and receiver modules

Dimension [mm]

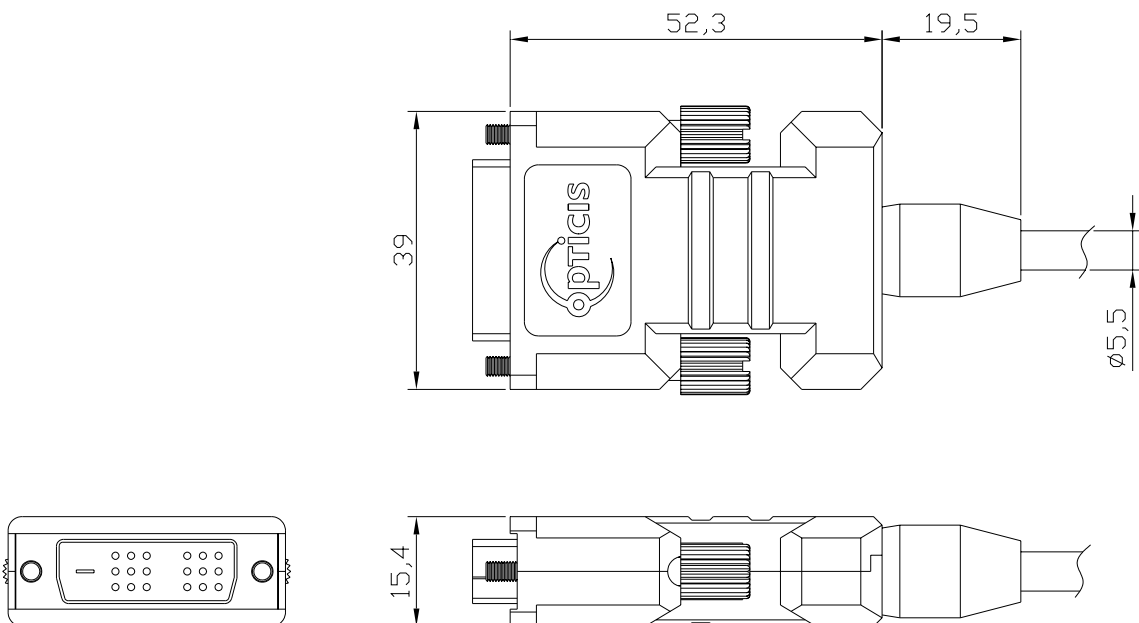

DVI Pin Description

Pin	Symbol	Functional Description
1	CH2-	TMDS Data Signal Channel 2 Negative
2	CH2+	TMDS Data Signal Channel 2 Positive
3	GND	TMDS Data Signal Channel 2 Shield
4		
5		
6	DDC Clock	DDC Clock line for DDC2B communication
7	DDC Data	DDC Data line for DDC2B communication
8	N.C.	
9	CH1-	TMDS Data Signal Channel 1 Negative
10	CH1+	TMDS Data Signal Channel 1 Positive
11	GND	TMDS Data Signal Channel 1 Shield
12		
13		
14	5 V	5 V Input for Transmitter from Host 5 V Output for Monitor from Receiver
15	GND	Ground
16	Hot plug Detect	Signal is driven by monitor to enable the system to identify the presence of a monitor
17	CH0-	TMDS Data Signal Channel 0 Negative
18	CH0+	TMDS Data Signal Channel 0 Positive
19	GND	TMDS Data Signal Channel 0 Shield
20		
21		
22	GND	TMDS Clock Signal Shield
23	CLK+	TMDS Clock Channel Positive
24	CLK-	TMDS Clock Channel Negative

Note: Channels 3, 4 and 5 dual-link data signal pins are not used

Reliability Test

Opticis utilizes three types of test criteria for a reduction of variability and a continuous improvement of the process by its FEMA (Failure Mode and Effective Analysis) program.

- 1) Mechanical test (vibration, shock)
- 2) Temperature & humidity tests
- 3) EMC test (*FCC class B and CE Verification*)

Mechanical and Temperature & Humidity Test Data

Heading	Test	Conditions	Duration	Sample Size	Failure	Remarks
Operating Test	Operating at each Temperature (See Note)	* -10 ~ 70 °C (Interval: 10 °C)	30 Min (Each Temperature)	n=3	0	Note: Visual Test on the Display
Storage Test	Low Temperature	* T _s = -30 °C	96 HR	n=3	0	1. TS: Storage Temperature
	High Temperature	* T _s = 80 °C	96 HR	n=3	0	2. RH: Relative Humidity
	High Humidity High Temperature	* T _s : 85 °C * RH: 85%	96 HR	n=3	0	
Mechanical Test	Mechanical Shock	* Pulse: 11 ms * Peak level: 30 g * Shock pulse: 3 times/Axis	-	n=2	0	
	Mechanical Vibration	* Peak acceleration: 20 g * Frequency: 20~2000 Hz * Sweep time: 30 Minutes * 4 Times/Axis	-	n=2	0	

EMC Test Data

1) EMI: Meet FCC class B (ICES-003) and CE class B

STANDARDS		CONDITIONS
EN 55 022 (CISPR22) FCC; PART 15 SUBPART B	CE (Conducted Emission) & RE (Radiated Emission)	Meet Class B
EN 61000-3-2 (IEC 61000-3-2)	Harmonics	Meet Class B
EN 61000-3-3 (IEC 61000-3-3)	Flickers	Meet Class B

2) EMS: Meet CE standards (EN 55024) and CISPR24 equivalents

STANDARDS		CONDITIONS
EN 61 000-4-2:1995	Electrostatic Discharge Immunity (Air: 8kv, Contact: 4kv)	Meet Criterion A
EN 61 000-4-3:1996	Radiated RF E-Field (80~1000 MHz) 3V/m (AM 80%, 1kHz)	Meet Criterion A
EN 61 000-4-4:1995	Fast Transients (5kHz, 60Seconds)	Meet Criterion A
EN 61 000-4-5:1995	Surge Transients	Meet Criterion A
EN 61 000-4-6:1996	Conducted Susceptibility (CS) Radiated Susceptibility (RS)	Meet Criterion A
EN 61 000-4-11:1994	Voltage Dips, Interruption & Variation	Meet Criterion A and C

Terminology

DDC	Digital Display Channel. Latest specification is DDC2B.
DVI-D	Digital Visual Interface. Digital connection only – no analog.
EDID	Extended Display Identification Data. EDID parameters are sent over the DDC link.
EMI	Electro Magnetic Interference.
EMS	Electro Magnetic Susceptibility.
HDCP	High Definition Content Protection. These parameters are part of the 2002 High Definition Multimedia Interface (HDMI) specification for Consumer Electronics.
PDP	Plasma Display Panel. Large HDTV panels up to 63" use this display technology.
RFI	Radio Frequency Interference.
TFT-LCD	Thin Film Transistor Liquid Crystal Display – the technology of most computer display panels with VESA resolutions up to 1600x1200 pixels.
TMDS	Transmission Minimized Differential Signalling is the Silicon Image Inc. protocol for the digital signals.
VCSEL	Vertical Cavity Surface Emitting Laser transmitter diode. The receiver diode is the PIN-Photo Diode. These components are designed and manufactured by Opticis.
VESA	Video Electronics Standards Association.