

DATA SHEET

Miniature Fiber Optic 3G-SDI Digital Video Extension Modules

Contents

- ◆ Description
- ◆ Features
- ◆ Applications
- ◆ Technical Specifications
- ◆ Drawing
- ◆ Cable Connection
- ◆ Environmental Reliability Test
- ◆ Terminology

OPTICIS HQ

Opticis Co., Ltd.

907, Byucksan Technopia, 434-6
Sangdaewon-Dong, Chungwon-Ku,
Sungnam City, Gyeonggi-Do, 462-716
South Korea
Te l: +82 (31) 737-8033~8
Fax: +82 (31) 737-8079

www.opticis.com
tosales@opticis.com

Fiber Optic 3G-SDI Extension Module

Description

OPTICIS miniature 3G-SDI extender is an optimized and high-end level solution designed for transmission of multi-rate 3G-SDI, HD-SDI, SDI and DVB-ASI digital video data over one (1) ST single-mode and multi-mode fiber. Supporting 1080p, 3G-SDI format, it converts and transmits one (1) channel of multi-rate SDI including SMPTE-424M (3G-SDI), SMPTE-292M (HD-SDI) or SMPTE-295M (SDI) perfectly up to 30km right after its transmitter receive the input signal. It also adopts ST terminated fiber-optic connector and SDI BNC input connector for suitable application and both modules guarantee the signal quality by equalizing and re-clocking features.

Due to the use of advanced digital fiber optic transmission technology, no user adjustments are required in the mini 3G-SDI extender system, enabling quick setup and trouble-free operation and because of latch-locking mechanism for power connector, no power disruption due to miss-handling problem. It comes with a rugged, standalone, miniature and metal die-casting enclosure type for harsh applications including broadcasting, medical, military and more for your world.

The modules are consisted of four (4) parts as follows;

- One transmitter converting digital video signal to optical signals, model name: SDIX-100-T, SDIX-100C-T
- One receiver converting optical signals to digital video signals, model name: SDIX-100-R
- One receiver converting optical signals to digital video signals including clock recovery, model name: SDIX-100C-R

The package includes as follows;

- Two modules of transmitter and receiver
- Two(2) DC 5V 1.5A Adaptors
- **PG-100 : 4-pin XLR male to mini XL female connector cable**
+12V power supply cable directly from camera (Option)
- User manual
- Plastic hard case

Features

- ◆ Supports multi-rate SDI up to 3G-SDI over one (1) fiber
- ◆ Extends up to 30km at 3Gbps
- ◆ Applicable to both single and multi-mode fibers
- ◆ Provides Clock and Data recovery (CDR) included model, SDIX-100C as an option
- ◆ SDI BNC input connector and ST terminated fiber optical connector
- ◆ Latch-locking power connector
- ◆ Robust metal die-casting enclosure for harsh environment
- ◆ Supports +5-16V DC of power range
- ◆ Available to get power from camera directly by PG-100
(50cm of 4-pin XLR male to mini XL female connector cable)
- ◆ Adopts up to 12 units in a 19" rack, BR-300 and BR-310

Applications

- ◆ Broadcast systems including remote/ENG/EFP and pre/post-production, studio to studio, camera to OB Vans, stadium to studio 3G-SDI digital video extension.
- ◆ Fiber optic applications with free-interference using 3G-SDI signals including medical, military, government and security purposes.

Technical Specifications

- General Specifications

	Parameter	Specifications
Components	Laser Diodes in TX Module	1310 FP laser diode
	Photo Diodes in RX Module	InGaAs/InP PIN photo diode
Electrical	Input and Output Signals	SMPTE 424M/292M/259M
	Data Transfer Rate (Graphic Data)	Max. 3Gbps
	Total Jitter at the end of Rx output	Max. 0.3UI
Optical	Propagation Delay	Max. 40ns
	Link Power Budget	Min 11dB
Connect	Optical Connector	ST Connector
	Electric Connector Type from Modules	75Ohm BNC (Male)
	Recommended Fiber	Standard single-mode fiber

- Absolute Maximum Ratings

Parameter	Symbol	Minimum	Maximum	Units
Supply Voltage	V _{CC}	+ 4.5	+5.5	V
Operating Temperature	T _{op}	-20	70	°C
Storage Temperature	T _{sto}	- 30	+ 85	°C
Storage Relative Humidity	RH _{sto}	5	95*	%RH

- **Operating Conditions**
Transmitter module (E-to-O converter) : SDIX-100-T

	Parameter	Symbol	Minimum	Typical	Maximum	Units
Power Supply	Supply Voltage	V _{CC}	4.5	5	5.5	V
	Supply Current	I _{TCC}		200		mA
	Power Dissipation	P _{TX}		1		W
	Power Supply Rejection (Note1)	PSR		50		mV _{p-p}
Electrical Link	Input Signal		SMPTE 424M/292M/259M			mV _{p-p}
	Input Impedance	Z _{IN}		75		Ω
	Input Signal Level		720	800	880	mV _{p-p}
	Return Loss		15			dB
	Propagation Delay				1.5	ns
	Data rate				3	Gbps
Optical Link	Output Optical Power	P _o	-9		-4	dBm
	Wavelength	λ	1290	1310	1330	nm
	Spectral width in RMS	Δλ			5	nm
	Extinction Ratio	Ext		8		dB
	Rising Time (Note2)	T _{rise}			135	ps
	Falling Time (Note2)	T _{fall}			135	ps
	Jitter in p-p value	T _{jitter}		100		ps

Note1. Tested with a 50mV_{p-p} sinusoidal signal in the frequency range from 500 Hz to 500 MHz on the V_{CC} supply with the recommended power supply filter in place. Typically less than a 0.25 dB change in sensitivity is experienced.

Note2. 20% - 80%; Measured unfiltered @ 3Gbps

Receiver module (O-to-E converter): SDIX-100-R

	Parameter	Symbol	Minimum	Typical	Maximum	Units
Power Supply	Supply Voltage	V _{CC}	4.5	5	5.5	V
	Supply Current	I _{TCC}		120		mA
	Power Dissipation	P _{TX}		0.6		W
	Power Supply Rejection (Note1)	PSR		50		mV _{p-p}
Electrical Link	Output Signal		SMPTE 424M/292M/259M			mV _{p-p}
	Output Impedance	Z _{IN}		75		Ω
	Output Signal Level		720	800	880	mV _{p-p}
	Return Loss		15			dB
	Propagation Delay				40	ns
	Data rate				3	Gbps
	Total Jitter	TR _{jitter}		0.2	0.3	UI
Optical Link	Receiving Optical Power	P _o	-20		0	dBm
	Wavelength	λ	1100	1310	1650	nm
	Power Budget	P _{bgt}		11		dB

Receiver module (O-to-E converter): SDIX-100C-R

	Parameter	Symbol	Minimum	Typical	Maximum	Units
Power Supply	Supply Voltage	V _{CC}	4.5	5	5.5	V
	Supply Current	I _{TCC}		220		mA
	Power Dissipation	P _{TX}		1.1		W
	Power Supply Rejection (Note1)	PSR		50		mV _{p-p}
Electrical Link	Output Signal		SMPTE 424M/292M/259M			mV _{p-p}
	Output Impedance	Z _{IN}		75		Ω
	Output Signal Level		720	800	880	mV _{p-p}
	Return Loss		15			dB
	Propagation Delay				40	ns
	Data rate				135	ps
	Total Jitter	TR _{jitter}		0.18	0.3	UI
Optical Link	Receiving Optical Power	P _o	-20		0	dBm
	Wavelength	λ	1100	1310	1650	nm
	Power Budget	P _{bgt}		11		dB

- Recommended Specifications of Fibre-Optic Cables

Parameters	Conditions	Specifications
Fibre Type	Glass single-mode Fiber	9.5± / 125±2μm
Modal Bandwidth	λ = 1310nm, 1550nm	Min. 400 MHz km
Fiber Cable Attenuation	λ = 1310nm, 1550nm	>0.3dB/km
No. of Ferrules	ST Connector	1 ferrules
Skew		2%
Insertion Attenuation		1.6%
Total Optical Attenuation		30mm

Drawing of Modules

Dimension [mm]

Copyright © 2011, All rights reserved by Opticis Co., Ltd.

2 Jun 2011

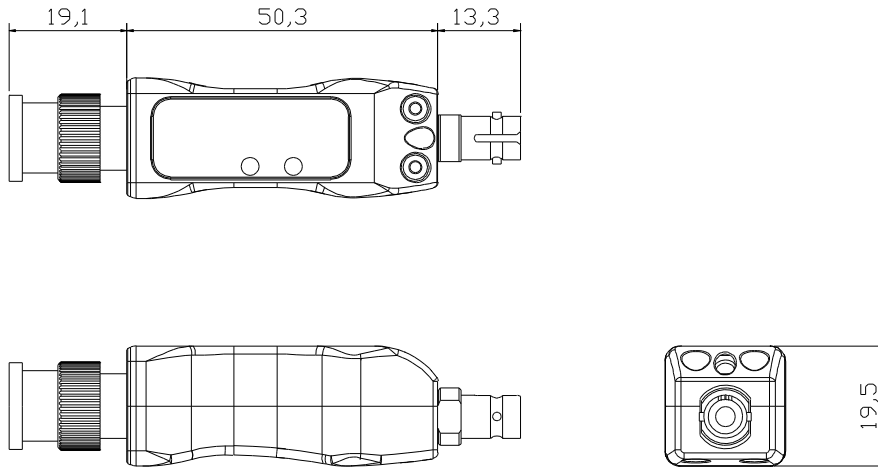

Note: The transmitter, SDIX-100-T and the receiver, SDIX-100C-R have the same mechanical dimensions.

Drawing of Cable Connections

The diagram shows the connection of transmitter (Tx; plug in PCs) and receiver (Rx; plug in displays) modules by using one (1) ST patch cord fiber.

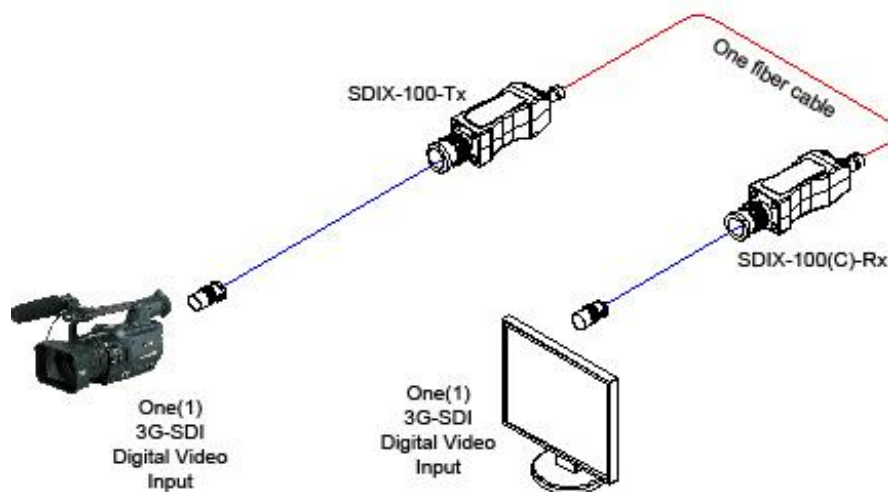

Reliability Test

Opticis utilizes three types of test criteria for a reduction of variability and a continuous improvement of the process by its FEMA (Failure Mode and Effective Analysis) program.

- 1) Mechanical test (vibration, shock)
- 2) Temperature & humidity tests
- 3) EMC test (*FCC class A Verification and CE Documentation*)

Mechanical and Temperature & Humidity Test Data

Heading	Test	Conditions	Duration	Sample Size	Failure	Remarks
<i>Operating Test</i>	Operating at each Temperature	* -20 ~ 70 °C (Interval: 10 °C)	30 Min (Each Temperature)	n =11	0	Note: Visual Test on the Display Pixel Error Rate
	High Temperature	* T _o = 80 °C	240 HR	n = 10	0	Note: Visual Test on the Display
<i>Storage Test</i>	Low Temperature	* T _s = -30 °C	96 HR	n=2	0	1. TS: Storage Temperature
	High Temperature	* T _s = 90 °C	96 HR	n=2	0	2. RH: Relative Humidity
	High Humidity High Temperature	* T _s : 85 °C * RH: 85%	96 HR	n=6	0	
<i>Mechanical Test</i>	Mechanical Shock	* Pulse: 11 ms * Peak level: 30 g * Shock pulse: 3 times/Axis	-	n=2	0	
	Mechanical Vibration	* Peak acceleration: 20 g * Frequency: 20~2000 Hz * Sweep time: 30 Minutes * 4 Times/Axis	-	n=2	0	

EMC Test Data

1) EMI: Meet FCC class A (ICES-003) and CE class A

STANDARDS		CONDITIONS
EN 55 022 (CISPR22) FCC; PART 15 SUBPART B	CE (Conducted Emission) & RE (Radiated Emission)	Meet Class A
EN 61000-3-2 (IEC 61000-3-2)	Harmonics	Meet Class A
EN 61000-3-3 (IEC 61000-3-3)	Flickers	Meet Class A

2) EMS: Meet CE standards (EN 55024) and CISPR24 equivalents

STANDARDS		CONDITIONS
EN 61 000-4-2:1995	Electrostatic Discharge Immunity (Air: 8kv, Contact: 4kv)	Meet Criterion B
EN 61 000-4-3:1996	Radiated RF E-Field (80~1000 MHz) 3V/m (AM 80%, 1kHz)	Meet Criterion A
EN 61 000-4-4:1995	Fast Transients (5kHz, 60Seconds)	Meet Criterion B
EN 61 000-4-5:1995	Surge Transients	Meet Criterion B
EN 61 000-4-6:1996	Conducted Susceptibility (CS) Radiated Susceptibility (RS)	Meet Criterion A
EN 61 000-4-11:1994	Voltage Dips, Interruption & Variation	Meet Criterion C

Terminology

- SDI Serial Digital Interface referring to a family of video interfaces standardized by SMPTE.
- SMPTE The Society of Motion Picture and Television Engineers or SMPTE, founded in 1916 as the Society of Motion Picture Engineers or SMPE, is an international professional association, based in the United States of America.
- SMPTE 424M Standard published by SMPTE expanding upon SMPTE 259M, SMPTE 344M, and SMPTE 292M allowing for bit-rates of 2.970 Gbit/s and 2.970/1.001 Gbit/s over a single-link coaxial cable. These bit-rates are sufficient for 1080p video at 50 or 60 frames per second. The signal formats carried over SMPTE 424M are specified in SMPTE 425M.
- EMI Electro Magnetic Interference.
- EMS Electro Magnetic Susceptibility.
- RFI Radio Frequency Interference.