

# DATA SHEET

## Optical Graphic Extension Module-Fibres Detachable

### Contents

- ◆ Description
- ◆ Features
- ◆ Applications
- ◆ Technical Specifications
- ◆ Functions
- ◆ Drawing
- ◆ Fiber Connection
- ◆ DVI Pin Description
- ◆ Reliability Test
- ◆ Terminology

#### Headquarter

Opticis Co., Ltd  
# 501, Byucksan Technopia, 434-6  
Sangdaewon-Dong, Chungwon-Ku,  
Sungnam City, Kyungki-Do, 463-120  
South Korea  
Tel: +82 (31) 737-8033~9  
Fax: +82 (31) 707-8079

[www.opticis.com](http://www.opticis.com)

#### North American Office

**Opticis North America, Inc.**  
330 Richmond Street, Suite 100,  
Chatham, Ontario  
CANADA N7M 1P7  
Tel : (519) 355-0819  
Fax : (519) 355-0520

Email : [roger@opticis.com](mailto:roger@opticis.com)

# Optical Graphic Extension Module

- Fibres Detachable -

## Description

The Digital Visual Interface is a high-quality, uncompressed data link protocol between a host processor video card and a display peripheral. Glass optical fiber (GOF) technology for this transmission stretches the performance beyond the limitations of copper wire with longer length, data security, negligible RFI/EMI and the elimination of costly analog distribution systems.

The EDID parameters in a display can be read and restored by plugging the Transmitter module into the display. This self-EDID programming feature virtual DDC (vDDC) feature makes the field installation of M1-201DA-TR easy and flexible for nearly all contemporary display systems.

The four DVI optical signals - Red, Green, Blue and Clock are multiplexed and de-multiplexed through Course Wave Division Multiplexing (CWDM) optical modules. The graphics data can be extended up to 1,500 meters (4,920ft) at WUXGA resolution (1900x1200), 60Hz vertical refresh rate over two (2) LC fibers.

An external +5VDC power adapter is likely required for the receiver module. Most video cards can provide +5V DC power to the transmitter module but it likewise has provision for external power. The transmitter and receiver modules are clearly labeled to prevent reverse installation of the modules.

The modules are constituted of three parts as follows;

- One transmitter converting electrical to optical signals, model name: M1-201DA-T
- One receiver converting optical to electrical signals, model name: M1-201DA-R
- Two AC Adaptors to 110V-240V with DC 5V 1A outlet

## Features

- ◆ Extends all DVI VESA resolutions up to WUXGA (1,920 X 1,200) 60Hz, as far as 1,500 meters (4,920 feet) with glass optical fibers.
- ◆ Works with both single-mode and multi-mode GOF fibers.
  - Up to 1,500m with two LC S-M fibers.
  - Up to 500m with two LC M-M fibers.
  - No copper wires in link.
- ◆ Has self-EDID programming feature - detecting from a display's DVI port and saving parameters to memory in the transmitter. vDDC requires no DDC connection between the Tx and Rx modules.
- ◆ The modules are compact in design to allow direct plugging into graphic cards and displays.
- ◆ Includes two +5V DC power adapters for the transmitter and receiver, if needed.
- ◆ FCC / CE certifications for EMI/RFI in place.

- ◆ Data security protection is optimal with glass optical fiber.
- ◆ Uncompressed, lossless video over the link.
- ◆ Complies with Class 1 Laser eye safety in compliance with FDA/CDRH and IEC 60825-1

## Applications

- ◆ Digital FPDs, PDPs and projectors for medical appliances, aero, traffic control, factory, and bank
- ◆ Digital FPDs and projectors in conference room and auditorium
- ◆ Kiosk with digital FPDs showing full motion graphic displays from remote systems
- ◆ PDP displays for information in public sites
- ◆ LED signboards in streets and in stadiums

## Technical Specifications

### - General Specifications

	Parameter	Specifications
Electrical	Input and Output Signals	TMDS Level (complying with DVI1.0)
	Data Transfer Rate (Graphic Data)	Max. 1.65Gbps
	Total Jitter at the end of Rx output	Max. 309 ps
	Skew inter-channels	Max. 6ns
Mechanical	Module dimension (mm)	69 X 39 X 15
Connect	Optical Connector	1 Duplex LC connectors
	Electric Connector Type from Systems and to Displays	24 pin DVI-D plug
	Recommended Fiber	9/125 um Single-mode Fiber or 50/125 um Multi-mode Glass Fiber

### - Absolute Maximum Ratings

Parameter	Symbol	Minimum	Maximum	Units
Supply Voltage	V <sub>CC</sub>	- 0.3	+ 6.0	V
Operating Temperature	T <sub>op</sub>	0	50	°C
Storage Temperature	T <sub>s</sub>	- 10	+ 85	°C
Storage Relative Humidity	H <sub>s</sub>	5	85	%RH

- **Electrical and Optical Characteristics**

**Transmitter module (E-to-O converter): M1-201DA-T**

	Parameter	Symbol	Minimum	Typical	Maximum	Units
Power Supply	Supply Voltage	V <sub>CC</sub>	4.5	5.0	5.5	V
	Supply Current	I <sub>TCC</sub>	350	430	570	mA
	Power Dissipation	P <sub>TX</sub>	1.5	2.2	3.2	W
	Power Supply Rejection (Note1)	PSR		50		mV <sub>p-p</sub>
TMDS	Data Output Load	R <sub>LD</sub>		50		Ω
	Graphic Supply Voltage (Note2)	GV <sub>CC</sub>	+ 3.1	+ 3.3	+ 3.5	V
	Single-Ended High Level Input Voltage	GV <sub>IH</sub>	GV <sub>CC</sub> - 0.01	GV <sub>CC</sub>	GV <sub>CC</sub> + 0.01	V
	Single-Ended Low Level Input Voltage	GV <sub>IL</sub>	GV <sub>CC</sub> - 0.6	-	GV <sub>CC</sub> - 0.4	V
	Single-Ended Input Swing Voltage	GV <sub>ISWING</sub>	0.4	-	0.6	V
Optical Link (Note3)	Output Optical Power	P <sub>o</sub>	-10.0		-3.0	dBm
	Wavelength	λ <sub>c1</sub>	1260	1310	1360	nm
		λ <sub>c2</sub>	1480	1550	1580	
	Relative Intensity of Noise (Note3)	RIN		-117		dB/Hz
	Extinction Ratio	Ext	4			dB
	Rising/Falling Time	T <sub>rise</sub> /T <sub>fall</sub>			260	ps
Jitter in p-p value (Note3)	T <sub>jitter</sub>			270	ps	

Note1. Tested with a 50mV<sub>p-p</sub> sinusoidal signal in the frequency range from 500 Hz to 500 MHz on the V<sub>CC</sub> supply with the recommended power supply filter in place. Typically less than a 0.25 dB change in sensitivity is experienced.

Note2. Graphic Supply Voltage is regulated reference voltage for signal processing in modules

Note3. Measure in 1GHz of frequency bandwidth

Note4. Use PPG (Pulse Pattern Generator) source with jitter 50ps

**Receiver module (O-to-E converter): M1-201DA-R**

	Parameter	Symbol	Minimum	Typical	Maximum	Units
Power Supply	Supply Voltage	V <sub>CC</sub>	4.5	5.0	5.5	V
	Supply Current	I <sub>RCC</sub>	350	430	570	mA
	Power Dissipation	P <sub>RX</sub>	1.5	2.2	3.2	W
	Power Supply Rejection (Note5)	PSR		50		mV <sub>p-p</sub>
TMDS	Data Input Load	R <sub>LD</sub>		50		Ω
	Graphic Supply Voltage (Note6)	GV <sub>CC</sub>	+ 3.1	+ 3.3	+ 3.5	V
	Single-Ended Output Swing Voltage (Note7)	GV <sub>ISWING</sub>	0.2	-	0.4	V
Optical Link (Notes9)	Receiving Optical Power	P <sub>o</sub>	-20		-3.6	dBm
	Receiving Wavelength	λ <sub>c1</sub>	1260	1310	1360	nm
		λ <sub>c2</sub>	1480	1550	1580	
	Signal_Detect Good	SDg			-17	dBm
	Signal_Detect Fail	SDf	-25			dBm
	Link Power Budget	P <sub>bgt</sub>	5			dB
Total Jitter (note 8)	TR <sub>jitter</sub>				309	ps

Note5. Tested with a 50mV<sub>p-p</sub> sinusoidal signal in the frequency range from 500 Hz to 500 MHz on the V<sub>CC</sub> supply with the recommended power supply filter in place. Typically less than a 0.25 dB change in sensitivity is experienced.

Note6. Graphic Supply Voltage is regulated reference voltage for signal processing in modules

Note7. TMDS outputs are coupled in AC

Note8. It is measured as total jitters including Tx and Rx modules under maximum extension, 500 meters with WUXGA 60Hz.

## Functions

### - Self-EDID Function

The EDID in a display can be read and restored by just plugging it to the display. This self-EDID programming feature makes the installation of M1-201DA more easy and flexible at any variable resolution display systems.

### - Auto Power Selection and Power Protection in Transmitter Module

The laser diodes are lit only when +5V voltage should be supplied into the 14-pin in DVI connectors.

The transmitter (Tx) module of M1-201CA-TR is designed a power protection circuit from conflict of power supply between the external DC power adapter and your graphic card through the DVI pin. It offers an option of whether to use an AC/DC power adapter depending on power supply capability of the graphic card through the +5V pin, you are using.

### - Signal Detect Mode in Receiver Module

It offers squelch function blocking output signals when optical input power is lower than as specified in a certain case, for instance, losing optical connectors.

## Drawing

Dimension [mm]

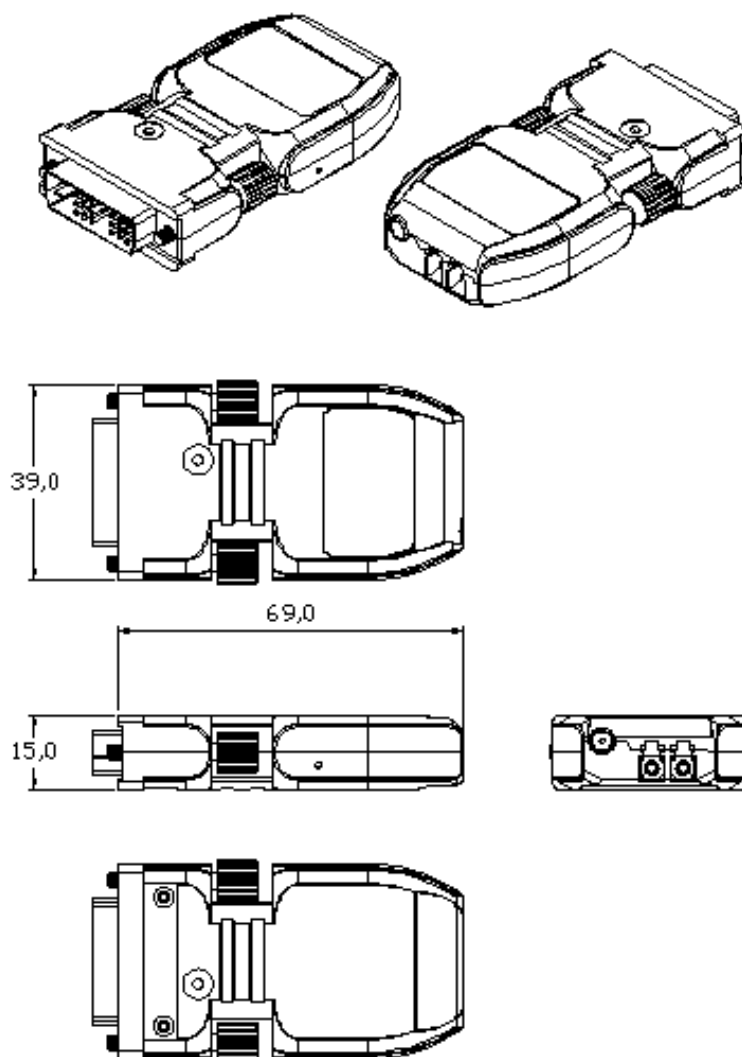

Note: The transmitter, M1-201DA-T and the receiver, M1-201DA-R have the same mechanical dimensions.

## Fiber Connection

The diagram shows the connection of transmitter (Tx; plug in PCs) and receiver (Rx; plug in displays) modules by using one dual LC patch cords fibers or 2 separate LC patch cord fibers.

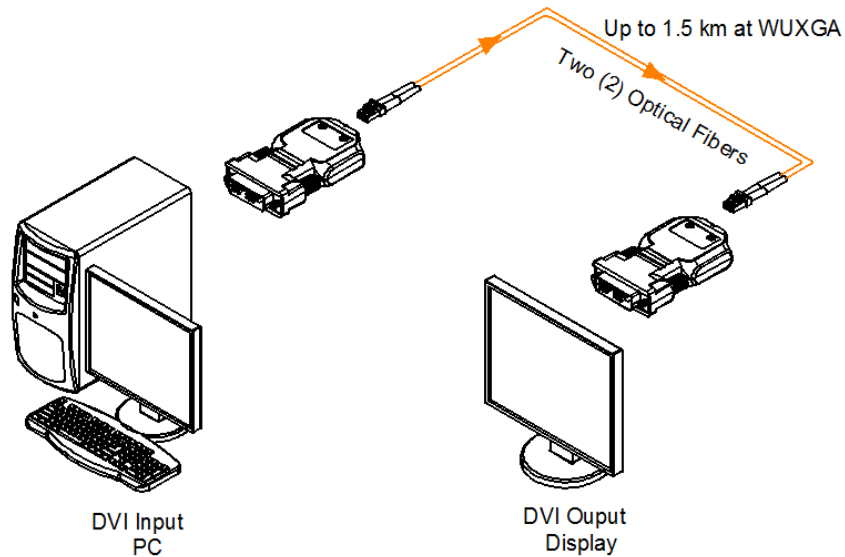

Warning; Dual LC patch cords made by some manufacturers could not fit in together since width of their plastic couplers are too wide to plug in M1-201DA-TR's LC receptacles. We recommend it to be 12.40 mm (not over 13.0mm).

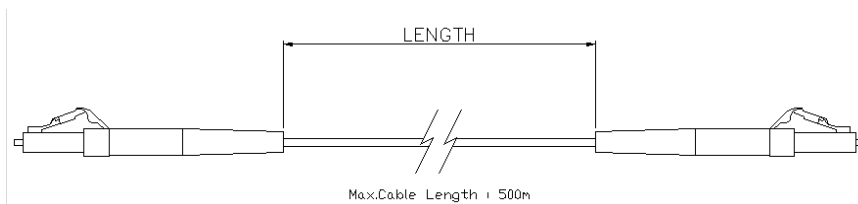
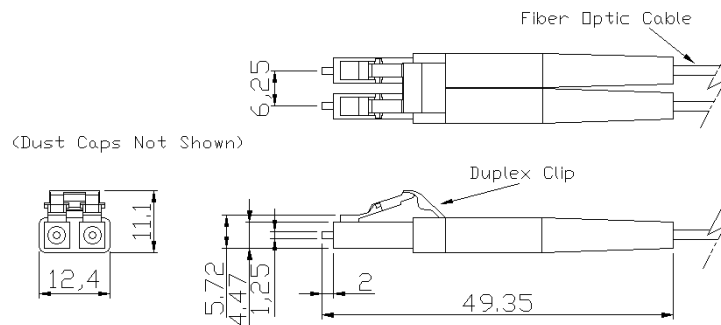

## DVI Pin Description

Pin	Symbol	Functional Description
1	CH2-	TMDS Data Signal Channel 2 Negative
2	CH2+	TMDS Data Signal Channel 2 Positive
3	GND	TMDS Data Signal Channel 2/4 Shield
4	CH4-	TMDS Data Signal Channel 4 Negative
5	CH4+	TMDS Data Signal Channel 4 Positive
6	DDC Clock	DDC Clock line for DDC2B communication
7	DDC Data	DDC Data line for DDC2B communication
8	N.C.	
9	CH1-	TMDS Data Signal Channel 1 Negative
10	CH1+	TMDS Data Signal Channel 1 Positive
11	GND	TMDS Data Signal Channel 1/3 Shield
12	CH3-	TMDS Data Signal Channel 3 Negative
13	CH3+	TMDS Data Signal Channel 3 Positive
14	5 V	Main Power Input for Transmitter from Host <sup>(Note10)</sup>
		5 V Output for Receiver to monitor
15	GND	Ground
16	Hot plug Detect	Signal is driven by monitor to enable the system to identify the presence of a monitor
17	CH0-	TMDS Data Signal Channel 0 Negative
18	CH0+	TMDS Data Signal Channel 0 Positive
19	GND	TMDS Data Signal Channel 0/5 Shield
20	CH5-	TMDS Data Signal Channel 5 Negative
21	CH5+	TMDS Data Signal Channel 5 Positive
22	GND	TMDS Clock Signal Shield
23	CLK+	TMDS Clock Channel Positive
24	CLK-	TMDS Clock Channel Negative

Note9) The AC-to-DC adapter for transmitter is option for Desk Top PC user.  
But Note PC user has to use the AC-to-DC adapter because the power of Note PC is not enough to drive M1-201DA transmitter.

## Reliability Test

Opticis utilizes three types of test criteria for a reduction of variability and a continuous improvement of the process by its FEMA (Failure Mode and Effective Analysis) program.

- 1) Mechanical test (vibration, shock)
- 2) Temperature & humidity tests
- 3) EMC test (*FCC class A Verification and CE Documentation*)

### Mechanical and Temperature & Humidity Test Data

Heading	Test	Conditions	Duration	Sample Size	Failure	Remarks
<i>Operating Test</i>	Operating at each Temperature	* 0 ~ 50 °C (Interval: 10 °C)	30 Min (Each Temperature)	n =11	0	Note: Visual Test on the Display Pixel Error Rate
	High Temperature	* T <sub>o</sub> = 70 °C	240 HR	n = 10	0	Note: Visual Test on the Display
<i>Storage Test</i>	Low Temperature	* T <sub>s</sub> = -30 °C	96 HR	n=2	0	1. TS: Storage Temperature
	High Temperature	* T <sub>s</sub> = 90 °C	96 HR	n=2	0	2. RH: Relative Humidity
	High Humidity High Temperature	* T <sub>s</sub> : 85 °C * RH: 85%	96 HR	n=6	0	
<i>Mechanical Test</i>	Mechanical Shock	* Pulse: 11 ms * Peak level: 30 g * Shock pulse: 3 times/Axis	-	n=2	0	
	Mechanical Vibration	* Peak acceleration: 20 g * Frequency: 20~2000 Hz * Sweep time: 30 Minutes * 4 Times/Axis	-	n=2	0	

## EMC Test Data

### 1) EMI: Meet FCC class A (ICES-003) and CE class A

STANDARDS		CONDITIONS
EN 55 022 (CISPR22) FCC; PART 15 SUBPART B	CE (Conducted Emission) & RE (Radiated Emission)	Meet Class A
EN 61000-3-2 (IEC 61000-3-2)	Harmonics	Meet Class A
EN 61000-3-3 (IEC 61000-3-3)	Flickers	Meet Class A

### 2) EMS: Meet CE standards (EN 55024) and CISPR24 equivalents

STANDARDS		CONDITIONS
EN 61 000-4-2:1995	Electrostatic Discharge Immunity (Air: 8kv, Contact: 4kv)	Meet Criterion B
EN 61 000-4-3:1996	Radiated RF E-Field (80~1000 MHz) 3V/m (AM 80%, 1kHz)	Meet Criterion A
EN 61 000-4-4:1995	Fast Transients (5kHz, 60Seconds)	Meet Criterion B
EN 61 000-4-5:1995	Surge Transients	Meet Criterion B
EN 61 000-4-6:1996	Conducted Susceptibility (CS) Radiated Susceptibility (RS)	Meet Criterion A
EN 61 000-4-11:1994	Voltage Dips, Interruption & Variation	Meet Criterion C

## Terminology

DDC	Digital Display Channel. Latest specification is DDC2B.
DVI-D	Digital Visual Interface. Digital connection only – no analog.
EDID	Extended Display Identification Data. EDID parameters are sent over the DDC link.
EMI	Electro Magnetic Interference.
EMS	Electro Magnetic Susceptibility.
HDCP	High Definition Content Protection. These parameters are part of the 2002 High Definition Multimedia Interface (HDMI) specification for Consumer Electronics.
PDP	Plasma Display Panel. Large HDTV panels up to 63" use this display technology.
RFI	Radio Frequency Interference.
TFT-LCD	Thin Film Transistor Liquid Crystal Display – the technology of most computer display panels with VESA resolutions up to 1600x1200 pixels.
TMDS	Transmission Minimized Differential Signalling is the Silicon Image Inc. protocol for the digital signals.
VCSEL	Vertical Cavity Surface Emitting Laser transmitter diode. The receiver diode is the PIN-Photo Diode. These components are designed and manufactured by Opticis.
VESA	Video Electronics Standards Association.