

# DATA SHEET

## One Fiber Detachable Optical Graphic Extension Module

### Contents

- ◆ Description
- ◆ Features
- ◆ Applications
- ◆ Technical Specifications
- ◆ Functions
- ◆ Drawing
- ◆ Fiber Connection
- ◆ DVI Pin Description
- ◆ Reliability Test
- ◆ Terminology

#### Headquarter

Opticis Co., Ltd  
# 501, ByucksanTechnopia, 434-6  
Sangdaewon-Dong, Chungwon-Ku,  
Sungnam City, Kyungki-Do, 463-120  
South Korea  
Tel: +82 (31) 737-8033~9  
Fax: +82 (31) 707-8079

[www.opticis.com](http://www.opticis.com)

#### North American Office

**Opticis North America, Inc.**  
330 Richmond Street, Suite 100,  
Chatham, Ontario  
CANADA N7M 1P7  
Tel : (519) 355-0819  
Fax : (519) 355-0520

Email : [roger@opticis.com](mailto:roger@opticis.com)

# Optical Graphic Extension Module

- One Fibre Detachable -

## Description

Optical graphic extension module consists of transmitter module and receiver module, each of which has a SC receptacle and a 20-pins DVI-D plug. Users could decide extension length at their discretion by choosing the length of fibre-optic cables with SC ferrules at the ends. It offers graphic TMDS signals to be extensible up to the limits of modal bandwidth of selected multi-mode glass fibers, or, 50/125 um or 62.5/125um.

The module has a capability to transmit WUXGA (1920X1200) graphic signals with 60Hz refresh rate using CWDM Optical Sub-Assembly (OSA) that transmits 4 data channels over only one multi-mode fibre. This module can extend up to 1,640 feet (500 meters) much over the limits of copper wire extension, without any distribution amplifier or repeater.

The EDID in a display can be read and restored by just plugging it to the display. This self-EDID programming feature makes the installation of M1-201CA more easy and flexible at any variable resolution display systems.

The modules are constituted of three parts as follows;

- One transmitter converting electrical to optical signals, model name: M1-201CA-T
- One receiver converting optical to electrical signals, model name: M1-201CA-R
- Two AC Adaptors to 110V-240V with DC 5V 1A outlet

## Features

- ◆ Extends all VESA resolution up to WUXGA (1920 X 1200) 60Hz DVI data up to 500 meters (1,640 feet)
- ◆ Detachable feature with only one multi-mode fiber
- ◆ Offers self-EDID programming feature, detecting from a display and restoring to an EEPROM in the transmitter just by plugging to the display without any physical DDC connection
- ◆ The modules are compact enough to directly plug to graphic sources and displays by adopting DVI-plugs
- ◆ Includes two (2) +5V DC power adapters for the transmitter and receiver
- ◆ Complies with Class 1 Laser eye safety in compliance with FDA/CDRH and IEC 60825-1
- ◆ Certifies FCC and CE standards for EMI/RFI emission
- ◆ Data security with negligible RFI/EMI emissions and loss of video quality due to no copper conductor present

## Applications

- ◆ Digital FPDs, PDPs and projectors for medical appliances, aero, traffic control, factory, and bank
- ◆ Digital FPDs and projectors in conference room and auditorium
- ◆ Kiosk with digital FPDs showing full motion graphic displays from remote systems
- ◆ PDP displays for information in public sites
- ◆ LED signboards in streets and in stadiums

## Technical Specifications

### - General Specifications

	Parameter	Specifications
Components	Laser Diodes in Tx Module	Multi-mode VCSEL (Vertical Cavity Surface Emitting Laser)
	Photo Diodes in Rx Module	GaAs PIN-PD
Electrical	Input and Output Signals	TMDS Level (complying with DVI1.0)
	Data Transfer Rate (Graphic Data)	Max. 1.65Gbps
	Total Jitter at the end of Rx output	Max. 309 ps
	Skew inter-channels	Max. 6ns
Optical	Link Power Budget	Min 10.5dB
Mechanical	Module dimension (mm)	36WX15HX65L
Connect	Optical Connector	1 SC connector
	Electric Connector Type from Systems and to Displays	24 pin DVI-D plug
	Recommended Fiber	50/125 um Multi-mode Glass Fiber

### - Absolute Maximum Ratings

Parameter	Symbol	Minimum	Maximum	Units
Supply Voltage	V <sub>CC</sub>	- 0.3	+ 6.0	V
Operating Temperature	T <sub>op</sub>	0	50	°C
Storage Temperature	T <sub>s</sub>	- 30	+ 70	°C
Storage Relative Humidity	H <sub>s</sub>	10	85	%RH

- **Operating Conditions**  
**Transmitter module (E-to-O converter): M1-201CA-T**

	Parameter	Symbol	Minimum	Typical	Maximum	Units
Power Supply	Supply Voltage	V <sub>CC</sub>	4.5	5.0	5.5	V
	Supply Current	I <sub>TCC</sub>	210	220	230	mA
	Power Dissipation	P <sub>TX</sub>	0.9	1.1	1.3	W
	Power Supply Rejection (Note1)	PSR		50		mV <sub>p-p</sub>
TMDS	Data Output Load	R <sub>LD</sub>		50		Ω
	Graphic Supply Voltage (Note2)	GV <sub>CC</sub>	+ 3.1	+ 3.3	+ 3.5	V
	Single-Ended High Level Input Voltage	GV <sub>IH</sub>	GV <sub>CC</sub> - 0.01	GV <sub>CC</sub>	GV <sub>CC</sub> + 0.01	V
	Single-Ended Low Level Input Voltage	GV <sub>IL</sub>	GV <sub>CC</sub> - 0.6	-	GV <sub>CC</sub> - 0.4	V
	Single-Ended Input Swing Voltage	GV <sub>ISWING</sub>	0.4	-	0.6	V
Optical Link (Notes3)	Output Optical Power	P <sub>o</sub>			+1.0	dBm
	Wavelength	λ	770		860	nm
	Spectral width in RMS	Δλ			0.5	nm
	Relative Intensity of Noise (Note4)	RIN		-117		dB/Hz
	Extinction Ratio	Ext	5			dB
	Rising/Falling Time	T <sub>rise</sub> /T <sub>fall</sub>			110	ps
	Jitter in p-p value (Note5)	T <sub>jitter</sub>			270	ps

Note1. Tested with a 50mV<sub>p-p</sub> sinusoidal signal in the frequency range from 500 Hz to 500 MHz on the V<sub>CC</sub> supply with the recommended power supply filter in place. Typically less than a 0.25 dB change in sensitivity is experienced.

Note2. Graphic Supply Voltage is regulated reference voltage for signal processing in modules

Note3. Measure signals at the end of 2 meter 50/125um MMGOF

Note4. Measure in 1GHz of frequency bandwidth

Note5. Use PPG (Pulse Pattern Generator) source with jitter 50ps

**Receiver module (O-to-E converter): M1-201CA-R**

	Parameter	Symbol	Minimum	Typical	Maximum	Units
Power Supply	Supply Voltage	V <sub>CC</sub>	4.5	5.0	5.5	V
	Supply Current	I <sub>RCC</sub>	210	220	230	mA
	Power Dissipation	P <sub>RX</sub>	0.95	1.1	1.27	W
	Power Supply Rejection (Note6)	PSR		50		mV <sub>p-p</sub>
TMD5	Data Input Load	R <sub>LD</sub>		50		Ω
	Graphic Supply Voltage (Note7)	GV <sub>CC</sub>	+ 3.1	+ 3.3	+ 3.5	V
	Single-Ended Output Swing Voltage (Note8)	GV <sub>ISWING</sub>	0.2	-	0.4	V
Optical Link (Note9)	Receiving Optical Power	P <sub>o</sub>	-14.0			dBm
	Receiving Wavelength	λ	770		860	nm
	Signal_Detect	SDg	-14		+1.0	dBm
	Link Power Budget	P <sub>bgt</sub>	10.5			dB
	Total Jitter (note 10)	TR <sub>jitter</sub>			309	ps

Note6. Tested with a 50mV<sub>p-p</sub> sinusoidal signal in the frequency range from 500 Hz to 500 MHz on the V<sub>CC</sub> supply with the recommended power supply filter in place. Typically less than a 0.25 dB change in sensitivity is experienced.

Note7. Graphic Supply Voltage is regulated reference voltage for signal processing in modules

Note8. TMD5 outputs are coupled in AC

Note9. Measure signals at the end of 2 meter 50/125um MMGOF

Note10. It is measured as total jitters including Tx and Rx modules under maximum extension, 500 meters with UXGA 60Hz.

**- Recommended Specifications of Fibre-Optic Cables**

Parameters	Conditions	Specifications
Fibre Type		50/125μm Multi-mode Graded Index Glass Fibre
Modal Bandwidth	λ = 850nm	Min. 400 MHz km
Fiber Cable Attenuation	λ = 850nm	Max. 3.5dB/km
Extension Distance		10 – 1650ft (500 meter)
Type of Ferrule	One SC ferrule	Standard SC ferrule
Skew		Max. 0.4ns
Insertion Attenuation		Max. 0.5dB
Total Optical Attenuation	In 330 ft (100 meter) extension	Max. 1.5dB

Note\*: some plastic couplers to clamp two LC connectors could not fit in.

## Functions

### - Self-EDID Function

The EDID in a display can be read and restored by just plugging it to the display. This self-EDID programming feature makes the installation of M1-201CA more easy and flexible at any variable resolution display systems.

### - Power Save Mode in Transmitter Module

The laser diodes are lit only when +5V voltage should be supplied into the 14-pin in DVI connectors. The voltage passing through a regulator has LD drive circuit work.

### - Signal Detect Mode in Receiver Module

It offers squelch function blocking output signals when optical input power is lower than as specified in a certain case, for instance, losing optical connectors.

## Drawing

Dimension [mm]

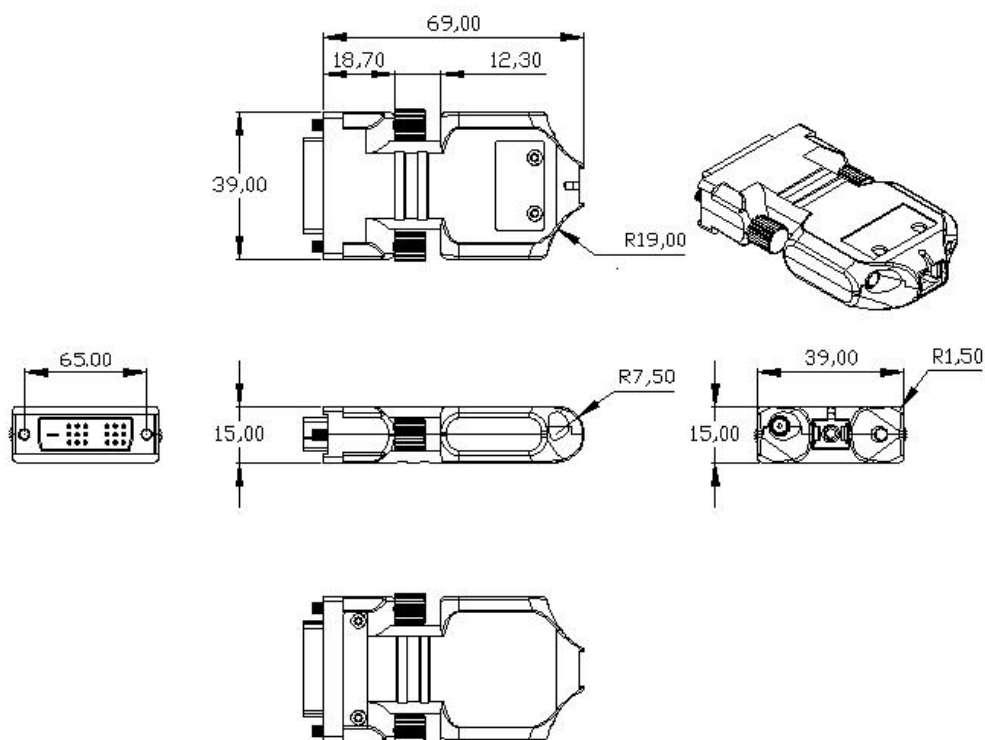

Note: The transmitter, M1-201CA-T and the receiver, M1-201CA-R has the same mechanical dimensions.

## Fiber Connection

The diagram shows the connection of transmitter (Tx; plug in PCs) and receiver (Rx; plug in displays) modules by using only one SC fibre.

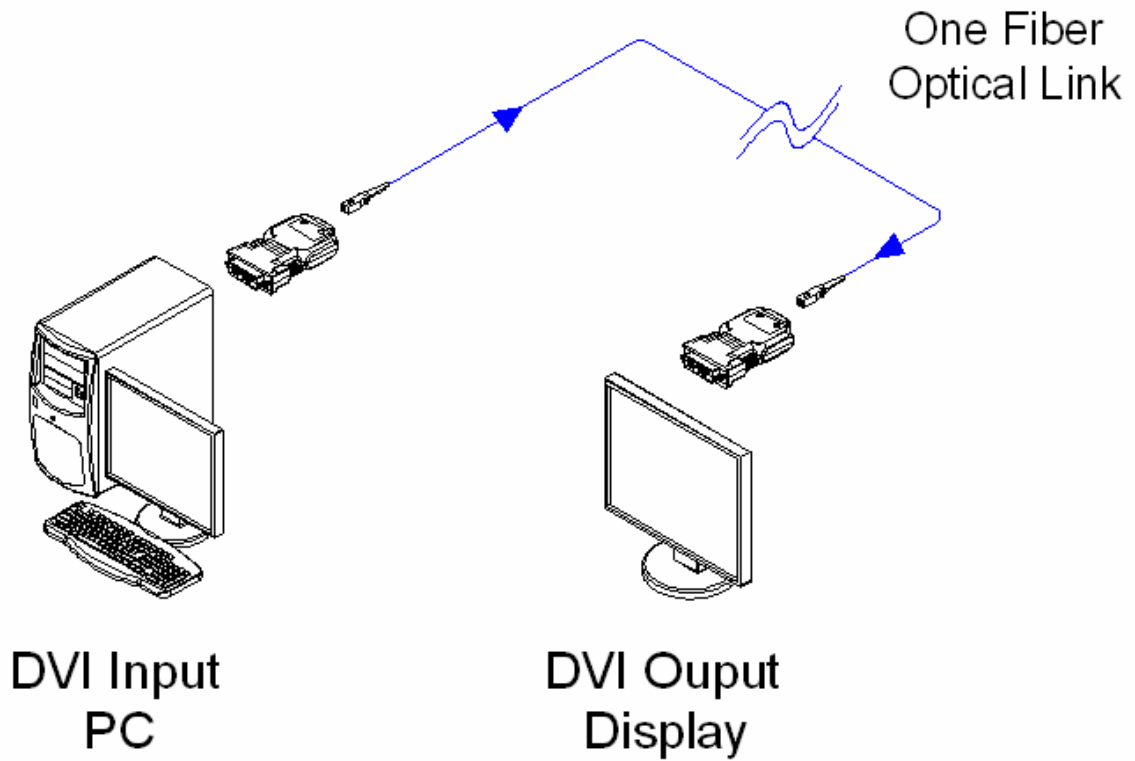

## DVI Pin Description

Pin	Symbol	Functional Description
1	CH2-	TMDS Data Signal Channel 2 Negative
2	CH2+	TMDS Data Signal Channel 2 Positive
3	GND	TMDS Data Signal Channel 2/4 Shield
4	CH4-	TMDS Data Signal Channel 4 Negative
5	CH4+	TMDS Data Signal Channel 4 Positive
6	DDC Clock	DDC Clock line for DDC2B communication
7	DDC Data	DDC Data line for DDC2B communication
8	N.C.	
9	CH1-	TMDS Data Signal Channel 1 Negative
10	CH1+	TMDS Data Signal Channel 1 Positive
11	GND	TMDS Data Signal Channel 1/3 Shield
12	CH3-	TMDS Data Signal Channel 3 Negative
13	CH3+	TMDS Data Signal Channel 3 Positive
14	5 V	Main Power Input for Transmitter from Host <sup>(Note10)</sup>
		5 V Output for Receiver to monitor
15	GND	Ground
16	Hot plug Detect	Signal is driven by monitor to enable the system to identify the presence of a monitor
17	CH0-	TMDS Data Signal Channel 0 Negative
18	CH0+	TMDS Data Signal Channel 0 Positive
19	GND	TMDS Data Signal Channel 0/5 Shield
20	CH5-	TMDS Data Signal Channel 5 Negative
21	CH5+	TMDS Data Signal Channel 5 Positive
22	GND	TMDS Clock Signal Shield
23	CLK+	TMDS Clock Channel Positive
24	CLK-	TMDS Clock Channel Negative

Note10) The AC-to-DC adapter for transmitter is option for Desk Top PC user.  
But Note PC user has to use the AC-to-DC adapter because the power of Note PC is not enough to drive M1-201SA transmitter.

## Reliability Test

Opticis utilizes three types of test criteria for a reduction of variability and a continuous improvement of the process by its FEMA (Failure Mode and Effective Analysis) program.

- 1) Mechanical test (vibration, shock)
- 2) Temperature & humidity tests
- 3) EMC test (*FCC class A Verification and CE Documentation*)

### Mechanical and Temperature & Humidity Test Data

Heading	Test	Conditions	Duration	Sample Size	Failure	Remarks
<i>Operating Test</i>	Operating at each Temperature	* 0 ~ 50 °C (Interval: 10 °C)	30 Min (Each Temperature)	n =11	0	Note: Visual Test on the Display Pixel Error Rate
	High Temperature	* T <sub>o</sub> = 70 °C	240 HR	n = 10	0	Note: Visual Test on the Display
<i>Storage Test</i>	Low Temperature	* T <sub>s</sub> = -30 °C	96 HR	n=2	0	1. TS: Storage Temperature
	High Temperature	* T <sub>s</sub> = 90 °C	96 HR	n=2	0	2. RH: Relative Humidity
	High Humidity High Temperature	* T <sub>s</sub> : 85 °C * RH: 85%	96 HR	n=6	0	
<i>Mechanical Test</i>	Mechanical Shock	* Pulse: 11 ms * Peak level: 30 g * Shock pulse: 3 times/Axis	-	n=2	0	
	Mechanical Vibration	* Peak acceleration: 20 g * Frequency: 20~2000 Hz * Sweep time: 30 Minutes * 4 Times/Axis	-	n=2	0	

**EMC Test Data**

**1) EMI: Meet FCC class B (ICES-003) and CE class B**

STANDARDS		CONDITIONS
EN 55 022 (CISPR22) FCC; PART 15 SUBPART B	CE (Conducted Emission) & RE (Radiated Emission)	Meet Class B
EN 61000-3-2 (IEC 61000-3-2)	Harmonics	Meet Class B
EN 61000-3-3 (IEC 61000-3-3)	Flickers	Meet Class B

**2) EMS: Meet CE standards (EN 55024) and CISPR24 equivalents**

STANDARDS		CONDITIONS
EN 61 000-4-2:1995	Electrostatic Discharge Immunity (Air: 8kv, Contact: 4kv)	Meet Criterion B
EN 61 000-4-3:1996	Radiated RF E-Field (80~1000 MHz) 3V/m (AM 80%, 1kHz)	Meet Criterion A
EN 61 000-4-4:1995	Fast Transients (5kHz, 60Seconds)	Meet Criterion B
EN 61 000-4-5:1995	Surge Transients	Meet Criterion B
EN 61 000-4-6:1996	Conducted Susceptibility (CS) Radiated Susceptibility (RS)	Meet Criterion A
EN 61 000-4-11:1994	Voltage Dips, Interruption & Variation	Meet Criterion C

**Terminology**

DDC	Digital Display Channel. Latest specification is DDC2B.
DVI-D	Digital Visual Interface. Digital connection only – no analog.
EDID	Extended Display Identification Data. EDID parameters are sent over the DDC link.
EMI	Electro Magnetic Interference.
EMS	Electro Magnetic Susceptibility.
HDCP	High Definition Content Protection. These parameters are part of the 2002 High Definition Multimedia Interface (HDMI) specification for Consumer Electronics.
PDP	Plasma Display Panel. Large HDTV panels up to 63” use this display technology.
RFI	Radio Frequency Interference.
TFT-LCD	Thin Film Transistor Liquid Crystal Display – the technology of most computer display panels with VESA resolutions up to 1600x1200 pixels.
TMDS	Transmission Minimized Differential Signalling is the Silicon Image Inc. protocol for the digital signals.
VCSEL	Vertical Cavity Surface Emitting Laser transmitter diode. The receiver diode is the PIN-Photo Diode. These components are designed and manufactured by Opticis.
VESA	Video Electronics Standards Association.