

DATA SHEET

Contents

- ◆ Features
- ◆ Description
- ◆ Absolute Maximum Ratings
- ◆ Transmitter & Receiver Electrical Interface
- ◆ Electrical Power Supply Characteristics
- ◆ Transmitter Performance Characteristics
- ◆ Receiver Performance Characteristics
- ◆ Mechanical Dimensions
- ◆ Ordering Information

Headquarter

Opticis Co., Ltd
501, ByucksanTechnopia, 434-6
Sangdaewon-Dong, Chungwon-Ku,
Sungnam City, Kyungki-Do, 463-120
South Korea
Tel: +82 (31) 737-8033~9
Fax: +82 (31) 707-8079

www.opticis.com

North American Office

Opticis North America Inc.
330 Richmond Street, Suite 100,
Chatham, Ontario N7M 1P7
Canada
Tel: +1 (519) 355-0819
Fax: +1 (519) 355-0502

850 nm VCSEL Transceivers for Low Voltage

Description

OPTICIS M3-250-LAT is a fiber optic transceiver, which meets the specifications defined in Gbit Ethernet as well as Fibre Channel. The transceiver offers a simple and convenient way to interface for Fibre Channel system running up to 2.5Gbps with multimode fiber optic cables. All modules satisfy Class I Laser Eye Safety requirements in accordance with the CDRH supervised by FDA in the US and international IEC-825 standards.

The transmitter and receiver functions are contained in a one-row, 10-pin (2x5) package with a Duplex LC receptacle. The transmitter employs a high performance 850 nm Vertical Cavity Surface Emitting Laser (VCSEL) with a driver circuit, which converts Positive Emitter Coupled Logic (PECL) data to light. The receiver incorporates a GaAs PIN photodiode converting the light signal into an electrical current, which is amplified and regenerated into PECL-compatible data. A Signal Detect status output is also provided in the receiver.

The transceiver is operated by +3.3V power supply over 0°C to +70°C. The transceiver package is made of metal (Duplex-LC version) for good EMI shielding.

Features

- ◆ Comply with IEEE Std.802.3z Gigabit Ethernet and Fibre Channel
- ◆ VCSEL(vertical cavity surface emitting laser) is adopted
- ◆ IEC 60825-1 Class 1 Laser Eye Safety
- ◆ Industry Standard 2x5 package style
- ◆ Duplex LC connector
- ◆ +3.3V Power Supply Operation with PECL logic data interface
- ◆ Compatible with commercial Gigabit Ethernet PHY transceiver chipsets
- ◆ Rugged package design by metal die-casting case

Equipments

- ◆ Switches
- ◆ Servers and Hubs
- ◆ Routers
- ◆ Repeaters

Applications

- ◆ Switch to switch Interface
- ◆ Switch to server links

Absolute Maximum Ratings

Parameter	Symbol	Minimum	Maximum	Units
Storage Temperature	Tstg	- 40	+ 85	°C
Supply Voltage	VCC	- 0.3	+ 3.8	V
Input Voltage	Vin	-0.3	VCC	V
Relative Humidity	RH	5	85	%
Lead Soldering Temperature & Time	-	-		260°C, 10 sec

Recommended Operating Conditions

Parameter	Symbol	Minimum	Typical	Maximum	Units
Ambient Operating Temperature	TA	0		+ 70	°C
Data Output Load	RLD		50		Ω
Power Supply Rejection ¹	PSR		50		mVpp
Supply Voltage	VCC	+3	+3.3	+3.6	V

¹ Tested with a 50mVp-p sinusoidal signal in the frequency range from 500 Hz to 500 MHz on the VCC supply with the recommended power supply filter in place. Typically less than a 0.25 dB change in sensitivity is experienced.

Transmitter Electrical Interface (Over Operating Temperature Range)

Parameter	Symbol	Minimum	Typical	Maximum	Units
Data Input Load	T _{LD}		50		Ω
Differential Input Voltage Swing	V _{ID}	0.4		1.6	V

Receiver Electrical Interface (Over Operating Temperature Range)

Parameter	Symbol	Minimum	Typical	Maximum	Units
Data Output Voltage Swing (Peak-to-Peak)	V _{Op-p}	0.6	-	0.8	V
Output High Voltage	V _{OH}	V _{CC} -1.02		V _{CC} -0.88	V
Output Low Voltage	V _{OL}	V _{CC} -1.8		V _{CC} -1.62	V

Electrical Power Supply Characteristics (Over Operating Temperature Range)

Parameter	Symbol	Minimum	Typical	Maximum	Units	
Supply Voltage	VCC	3.1	3.3	3.5	V	
Supply Current	TX	ICT	-	60	70	mA
	RX	ICR	-	85	100	mA

Transmitter Performance Characteristics (Over Operating Temperature)

50 μ /125, 62.5 μ /125 multi mode GOF

Parameter	Symbol	Minimum	Typical	Maximum	Units
Data Rate ¹	B	-	2.5	-	Gb/s
Average launch Power ²	P _o	-9.5	-	-	dBm
Wavelength	λ_c	840	850	860	nm
Spectral Width (RMS)	$\Delta\lambda_{RMS}$	-	-	0.85	nm
Coupled Power Ratio ³	CPR	9	-	-	dB
Extinction Ratio		-	9	-	dB
Output Rise Time ⁴	T _{TLH}	-	-	125	ps
Output Fall Time ⁴	T _{THL}	-	-	130	ps
Relative Intensity Noise	RIN	-	-	-117	dB/Hz

- 1 Transmitter is shut off when transmitting continuous "zero". Power supply does not need to be reset to reactivate the transmitter. Transmitter is also shut off when transmitting continuous "one". However, power supply needs to be reset to reactivate the transmitter.
2 The maximum launch power shall be the lesser of the class 1 Eye safety limit as defined by IEEE Std. 802.3z.
3 CPR measured per TIA/EIA OFSTP-14A with valid 8B/10B data pattern
4 Measured from 20% to 80% levels on rising and falling edge of transmitted waveform.

Receiver Performance Characteristics (Over Operating Temperature)

50 μ /125, 62.5 μ /125 multi mode GOF

Parameter	Symbol	Minimum	Typical	Maximum	Units
Data Rate	B	-	2.5	-	Gb/s
Receive Sensitivity (10 ⁻¹² BER)	-	-22	-20	-17	dBm
Average Receive Power	-	-	-	0	dBm
Stressed Receiver Sensitivity	50um Fiber	-	-13.5	-	dBm
	62.5um Fiber	-	-12.5	-	dBm
Output Rise Time ¹	T _{RLH}	-	-	100	ps
Output Fall Time ¹	T _{RHL}	-	-	100	ps
Wavelength of Operation	λ	600	850	900	nm
Return Loss ²	-	12	-	-	dB

- 1 Measured from 20% to 80% levels on rising and falling edge of receiver output waveform
2 Return loss is defined as the minimum attenuation (dB) of received optical power for energy reflected back into the optical fiber.

Mechanical Dimensions [mm]

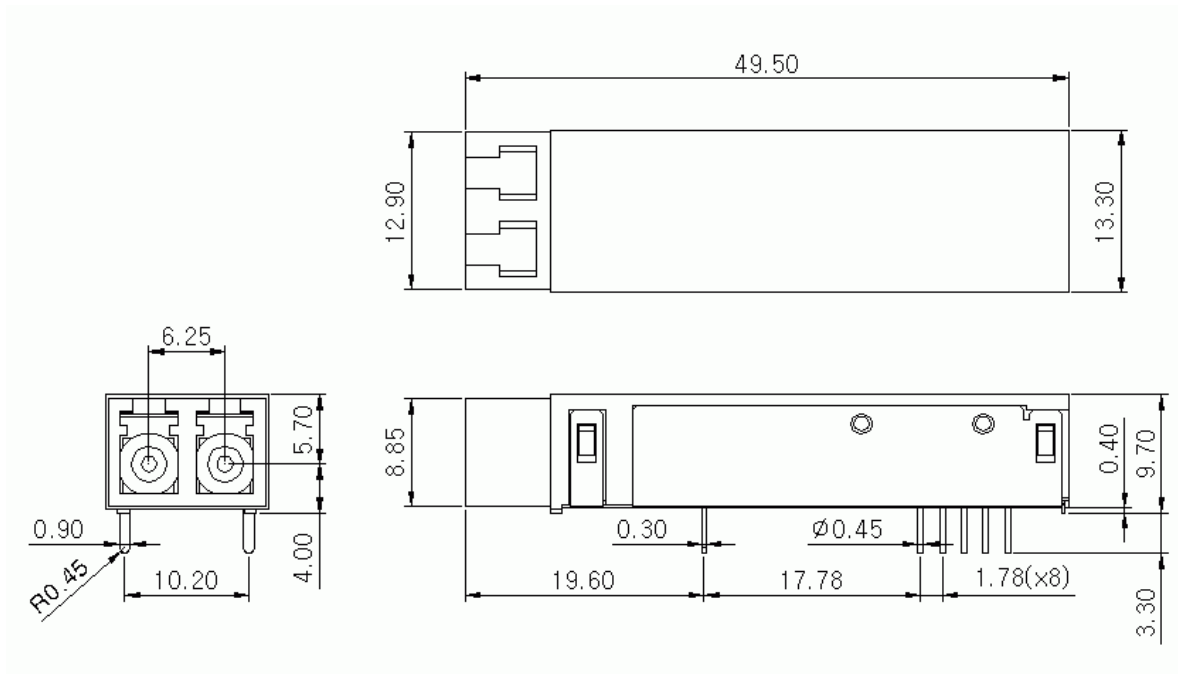

Shield

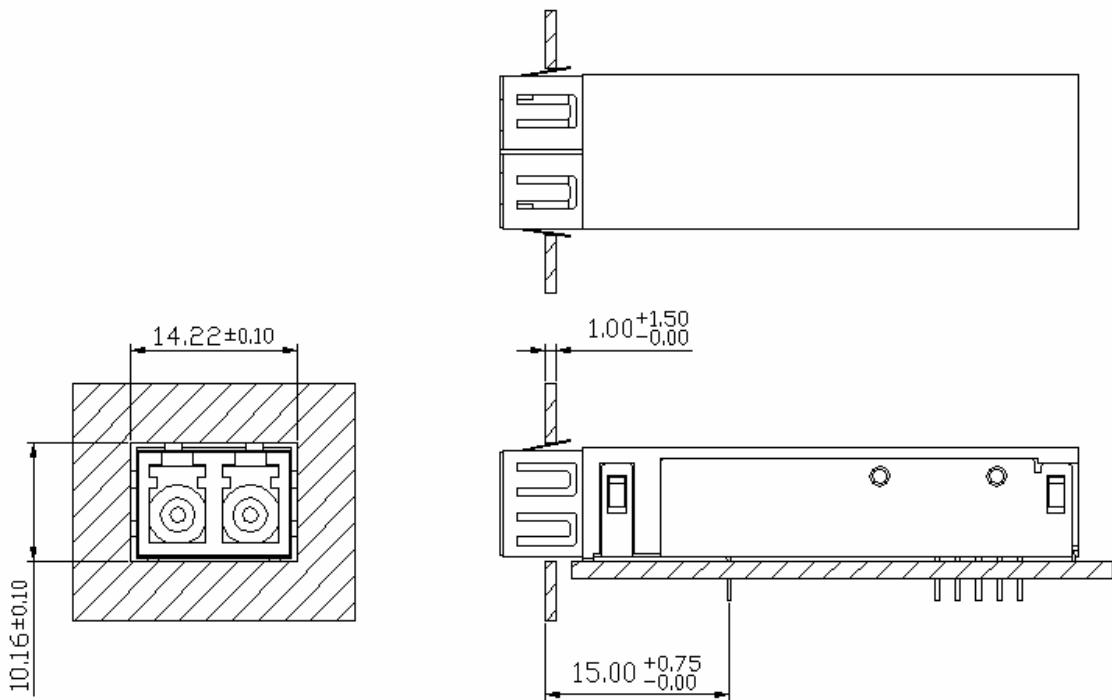

Pin Assignments



Pin	Symbol	Functional Description
1	V _{EER}	Receiver Signal Ground Directly connect this pin to receiver signal ground plane.
2	V _{CCR}	Receiver Power Supply Provide +3.3V via the recommended receiver power supply filter circuit. Locate the power supply filter circuit as close as possible to the V _{CCR} pin.
3	SD	Signal Detect Signal Detect is a single-ended LVTTTL output.(ECL output available) Normal optical input levels to the receiver result in a logic "1" output, VOH, asserted. Low input optical levels to the receiver result in a fault condition indicated by a logic "0" output VOL, de-asserted. If Signal Detect output is not used, leave it open-circuited.
4	RD-	Receiver Data Out-Bar AC coupled - PECL compatible
5	RD+	Receiver Data Out AC coupled - PECL compatible
6	V _{CCT}	Transmitter Power Supply Provide +3.3V via the recommended transmitter power supply filter circuit. Locate the power supply filter circuit as close as possible to the V _{CCT} pin.
7	V _{EET}	Transmitter Signal Ground Directly connect this pin to the transmitter signal ground plane.
8	TDis	Transmitter Disable
9	TD+	Transmitter Data In AC or DC coupled - PECL compatible
10	TD-	Transmitter Data In-Bar AC or DC coupled - PECL compatible

Ordering Information

M3-XXX-ABC

XXX: 106 and 125 stand for 1.0615Gbit data rate for Fibre Channel
and 1.25Gbit data rate for Gbit Ethernet, respectively.

212 and 250 stand for 2.125Gbit data rate for Fibre Channel
and 2.5Gbit data rate for Gbit Ethernet, respectively.

A : Connector style, that is, S for SC and L for LC and M for MTRJ.

B : Receiver termination, that is, A for AC coupling and D for DC coupling

C : Signal Detect Level, that is, P for PECL and T for TTL

Application Notes

Transmitter : When the Tdis is Low or Floating and TD+ input is at logic HIGH and TD- input is at logic LOW, the LD is ON, and vice versa. Transmitter input is AC coupled. The center value for the input voltage is set by the user and can be ECL, PECL, etc.

Receiver: Both differential RD+ and RD- outputs are AC coupled. For optimum performance, both outputs should be terminated in the same manner, even if only one is used. The SD circuit monitors the level of the incoming optical signal and generates a logic LOW signal when insufficient photocurrent is produced.

Interface circuit: The power supply line should be well filtered. All 0.1 μ F power supply bypass capacitors should be as close to the M3-125-SL-LA transceiver modules as possible(OPTICIS 2X5 evaluation board recommended). The two front GND posts should be grounded to system Ground.

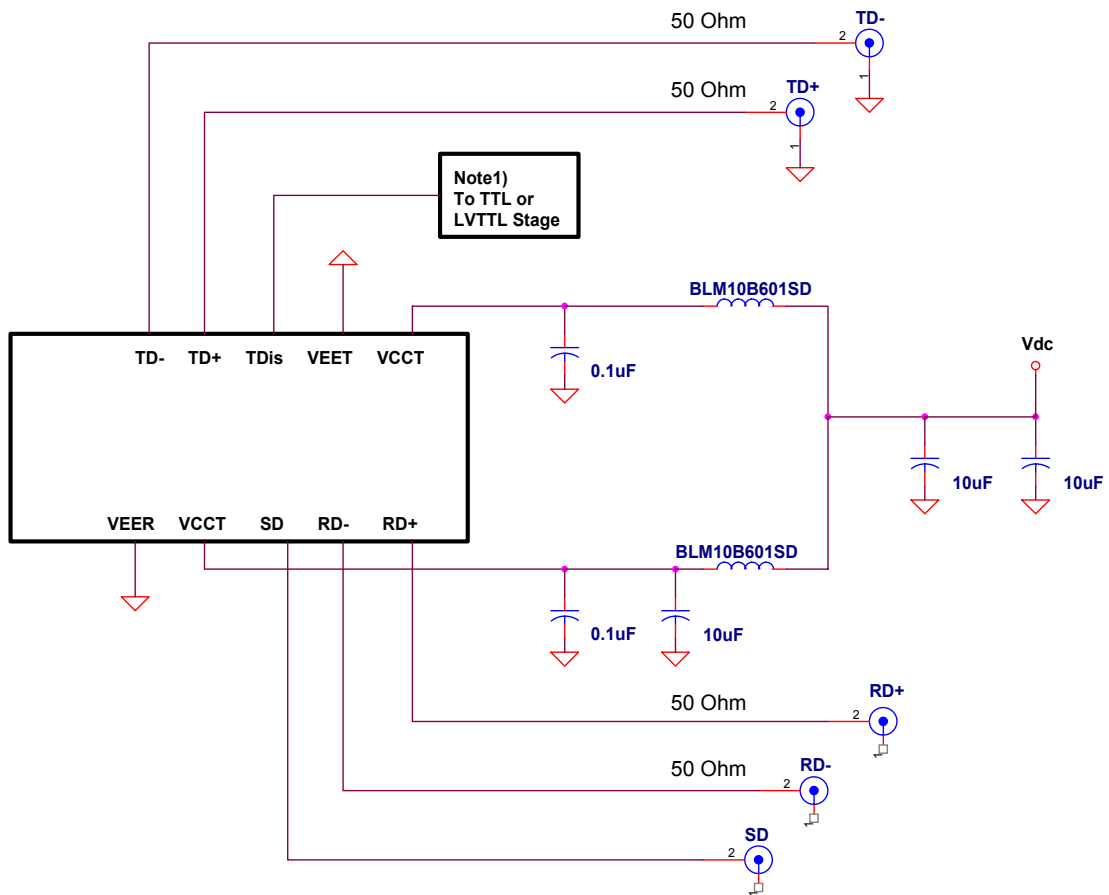

Note1) Transmitter disable : LVTTTL(3.3V)

Normal Operation : Logic "0" , or Open Circuit(Floating) → LD ON

Transmitter Disable : Logic "1" → LD Off

*** Transmitter can be disabled by connecting Pin8 to VCCT via a 500 Ohm resistor.