

# DATA SHEET

## Contents

- ◆ Description
- ◆ Features
- ◆ Application
- ◆ PIN Information
- ◆ Module Performance Characteristics
- ◆ Timing Requirements of Control and Status I/O
- ◆ Serial ID
- ◆ Mechanical Dimensions
- ◆ Ordering Information

### Headquarter

Opticis Co., Ltd  
# 501, ByucksanTechnopia, 434-6  
Sangdaewon-Dong, Chungwon-Ku,  
Sungnam City, Kyungki-Do, 463-120  
South Korea  
Tel: +82 (31) 737-8033~9  
Fax: +82 (31) 707-8079

[www.opticis.com](http://www.opticis.com)

### North American Office

Opticis North America Inc.  
  
330 Richmond Street, Suite 100,  
Chatham, Ontario N7M 1P7  
Canada  
  
Tel: +1 (519) 355-0819  
Fax: +1 (519) 355-0502

# **2.5Gbps 850nm VCSEL Small Form Factor Pluggable Transceiver**

## **Description**

OPTICIS M3-250-PAT is a fiber optic transceiver, which meets the specifications defined in Gbit Ethernet as well as Fibre Channel. The transceiver offers a simple and convenient way to interface for Fibre Channel system running up to 2.5Gbps with multimode fiber optic cables. All modules satisfy Class I Laser Eye Safety requirements in accordance with the CDRH supervised by FDA in the US and international IEC-825 standards. This transceiver is compliant with the Small Form Factor Pluggable (SFP) specification. The transmitter employs a high performance 850 nm Vertical Cavity Surface Emitting Laser (VCSEL) with a driver circuit, which converts Pseudo Emitter Coupled Logic (PECL) data to light. The receiver incorporates a GaAs PIN photodiode converting the light signal into an electrical current, which is amplified and regenerated into PECL-compatible data. A Signal Detect status output is also provided in the receiver. The transceiver is operated by +3.3V power supply over 0°C to +70°C. The transceiver package is made of metal case for good EMI shielding.

## **Features**

- ◆ Single 3.3volt Power Supply
- ◆ 850nm Vertical Cavity Surface Emitting Laser (VCSEL) Source
- ◆ Compliant with InfiniBand™ Architecture (IBA) IB-1X-SX at 2.5Gbps
- ◆ Compliant with IEEE 802.3z Gigabit Ethernet (1000Base-SX) at 1.25Gbps
- ◆ Compliant with Small Form Factor Pluggable (SFP) MultiSource Agreement
- ◆ AC coupled LVPECL differential inputs and outputs
- ◆ Supports Serial ID
- ◆ Operates with 50µm and 62.5µm multimode optical fibers
- ◆ Metallized Case for the good EMI performance
- ◆ Class 1 FDA and IEC Laser Safety Compliant

## Applications

- ◆ Data Communication Networks
- ◆ Network Interface Cards
- ◆ High Performance Desktops
- ◆ Storage Area Network (SAN)

## Pin Information

Pin	Symbol	Sequence	Type	Functional Description
1	VeeT	1	Ground	Transmitter signal ground
2	TX Fault	3	Signal Out	Transmitter fault indication
3	TX Disable	3	Signal In	Transmitter disable
4	MOD_DEF2	3	Input/Output	Module definition 2
5	MOD_DEF1	3	Input/Output	Module definition 1
6	MOD_DEF0	3	Input/Output	Module definition 0
7	Rate Select	3	Not Connected	Select between full or reduced receiver bandwidth
8	LOS	3	Signal Out	Loss of signal
9	VeeR	1	Ground	Receiver ground
10	VeeR	1	Ground	Receiver ground
11	VeeR	1	Ground	Receiver ground
12	RD-	3	Data Out	Received data inverted output
13	RD+	3	Data Out	Received data non-inverted output
14	VeeR	1	Ground	Receiver ground
15	VccR	2	Power	+3.3V Receiver power supply
16	VccT	2	Power	+3.3V Transmitter power supply
17	VeeT	1	Ground	Transmitter ground
18	TD+	3	Data In	Transmitter data non-inverted output
19	TD-	3	Data In	Transmitter data inverted output
20	VeeT	1	Ground	Transmitter ground

### Notes:

- 1) TX Fault is an open collector/drain output, which should be pulled up with a 4.7K ~ 10K $\Omega$  resistor on the host board. When high, output indicates a laser fault of some kind.  
Low indicates normal operation. In the low state, the output will be pulled to < 0.8V.
- 2) TX disable is an input that is used to shut down the transmitter optical output. It is pulled up within the module with a 4.7K ~ 10K $\Omega$  resistor. Its states are:  
Low (0 ~ 0.8V) : Transmitter on  
(>0.8, < 2.0V) : Undefined  
High (2.0 ~ 3.465V) : Transmitter Disabled  
Open : Transmitter Disabled
- 3) Mod-Def 0,1,2. These are the module definition pins. They should be pulled up with a 4.7K ~ 10K $\Omega$  resistor on the host board. The pull-up voltage shall be VccT or VccR.  
Mod-Def 0 is grounded by the module to indicate that the module is present Mod-Def 1 is the clock line of two wire serial interface for serial ID Mod-Def 2 is the data line of two wire serial interface for serial ID.

- 4) LOS(Loss of Signal) is an open collector/drain output, which should be pulled up with a 4.7K ~ 10K $\Omega$  resistor. When high, this output indicates the received optical power is below the worst-case receiver sensitivity. Low indicates normal operation. In the low state, the output will be pulled to < 0.8V.
- 5) VeeR and VeeT may be internally connected within the SFP module.
- 6) Rx\_Data-/+ : These are the differential receiver outputs. They are AC coupled 100 $\Omega$  differential lines which should be terminated with 100 $\Omega$  (differential) at the user SERDES. The AC coupling is done inside the module and is thus not required on the host board. The voltage swing on these lines will be between 600 and 800 mV differential when properly terminated.
- 7) VccR and VccT are the receiver and transmitter power supplies. They are defined as 3.3V $\pm$ 5% at the SFP connector pin. Maximum supply current is 300 mA. Recommended host board power supply filtering is shown below. Inductors with DC resistance of less than 1 $\Omega$  should be used in order to maintain the required voltage at the SFP input pin with 3.3V supply voltage. When the recommended supply filtering network is used, hot plugging of the SFP transceiver module will result in an inrush current of no more than 30 mA greater than the steady state value. VccR and VccT may be internally connected within the SFP transceiver module.
- 8) Tx\_Data-/+ : These are the differential transmitter inputs. They are AC-coupled, differential lines with 100 $\Omega$  differential termination inside the module. The AC coupling is done inside the module and is thus not required on the host board. The inputs will accept differential swings of 200 – 1660 mV, though it is recommended that values between 500 and 1200 mV differential be used for best EMI performance.

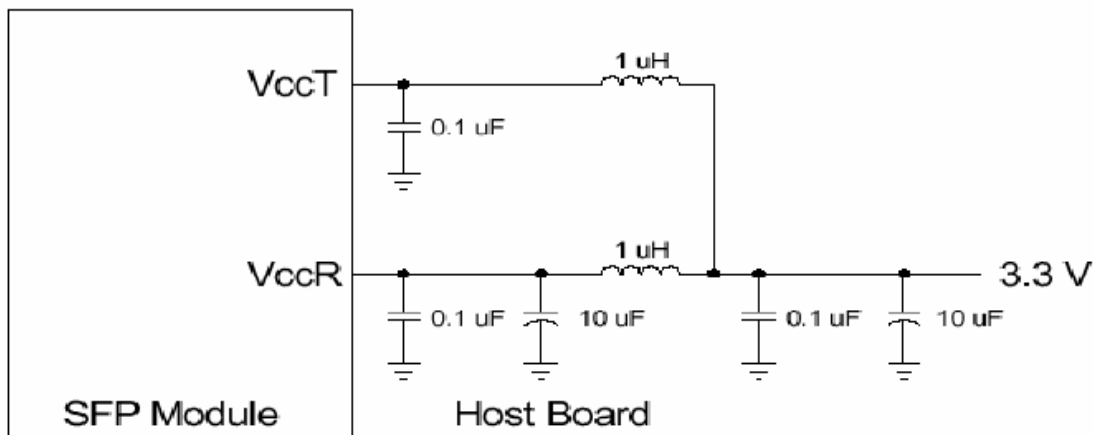

**Figure 1. Recommended Host Board Supply Filtering Network**

**Application Circuit**

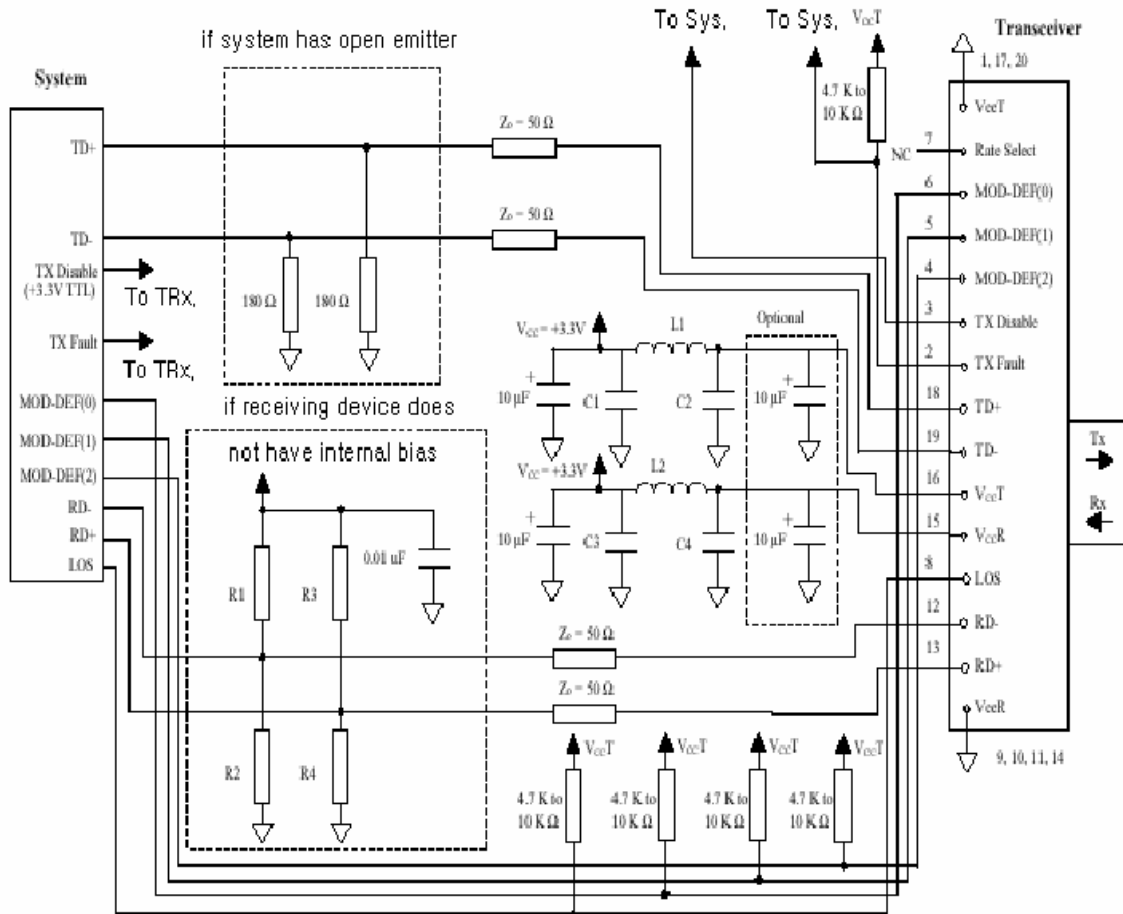

**Figure 2. Example SFP Host Board Schematics**

In order to prevent unwanted reflections between system and transceiver, it is necessary to have both a 50Ω impedance matched transmission line as well as a 50Ω termination load. The system board differential pair transmission lines must be designed with the same length. The transmitter internally includes a 100Ω differential termination for the two differential input lines (TD+, TD-). Therefore, additional 50Ω terminations should not be externally connected to the transmitter-input lines. The transmitter is disabled when the TX disable is TTL high and enabled when TTL low. If this feature is not needed, it should be connected to system ground.

## Module Performance Characteristics

### Transmitter Electro-Optical Characteristics

(TA=0°C to 70°C, Vcc=3.3volt)

Parameter	Symbol	Min	Typ	Max	Unit	Note
Supply current	Ic			100	mA	
Launched average power	Po	-9.5		-4	dBm	
Center wavelength	$\lambda_c$	830	850	860	nm	VCSEL
Spectral width(RMS)	$\delta$			0.85	nm	
Relative intensity noise	RIN			-117	dB/Hz	
Extinction ratio	ER	9			dB	
Rise/Fall time	tR/tF			0.15	ns	20-80%
Optical modulation amplitude	OMA	200			$\mu$ W	
Optical contributed jitter(total)	TJ			150	ps	

### Receiver Electro-Optical Characteristics

(TA=0°C to 70°C, Vcc=3.3volt)

Parameter	Symbol	Min	Typ	Max	Unit	Note
Supply current	Ic			200	mA	
Minimum Optical input power(sensitivity)	PMIN			-17	dBm	
Maximum Optical input power(saturation)	PMAX			-1.5	dBm	
Return loss of receiver		12			dB	
Loss of Signal- asserted	PA		-22	-18	dBm	
Loss of Signal-deasserted	PD	-26	-24		dBm	
Loss of Signal-hysteresis	PA-PD		2	3	dB	

### Absolute Maximum Ratings

These are absolute maximum ratings only. Higher stress than these ratings may adversely affect device reliability or cause permanent damage to the device.

Parameter	Symbol	Min	Typ	Max	Unit	Note
Storage temperature	TS	-40		85	°C	
Soldering temperature				260	°C	6sec.on leads only
Supply voltage	Vcc			3.8	V	

## Operating Environment

Parameter	Symbol	Min	Typ	Max	Unit	Note
Ambient temperature	TA	0		70	°C	
Supply voltage	Vcc-Vee	3.1		3.6	V	
Transmitter Differential Input voltage	VD	0.6		2.4	V	

### TIMING REQUIREMENTS OF CONTROL AND STATUS I/O

PARAMETER	SYMBOL	MIN.	MAX.	UNIT	CONDITIONS
Tx Disable assert time	t <sub>off</sub>		10	μs	Timing from rising edge of Tx Disable to when the optical output falls below 10% of nominal
Tx Disable Negate time	t <sub>on</sub>		1	ms	Timing from falling edge of Tx Disable to when the modulated optical output rises above 90% of nominal
Time to initialize Includes reset of Tx Fault	t <sub>init</sub>		300	ms	From power on or negation of Tx Fault using Tx Disable
Tx Fault Assert time	t <sub>fault</sub>		100	μs	Time from fault to Tx Fault on
Tx Disable to Reset	t <sub>reset</sub>	10		μs	Time Tx Disable must be held high to reset Tx Fault
Los Assert time	t <sub>loss_on</sub>		100	μs	Time from LOS state to Rx Los assert
Los Deassert time	t <sub>loss_off</sub>		1000	μs	Time from non-LOS state to Rx Los deassert
Rate select Change time	t <sub>ratesel</sub>		100	μs	Timing from rising or falling edge of rate select input until receiver bandwidth is in conformance with appropriate specification
Serial ID clock rate	f <sub>s_clock</sub>		100	KHz	

The power on initialization timing for a transceiver with TX\_DISABLE negated is shown in Figure 3.

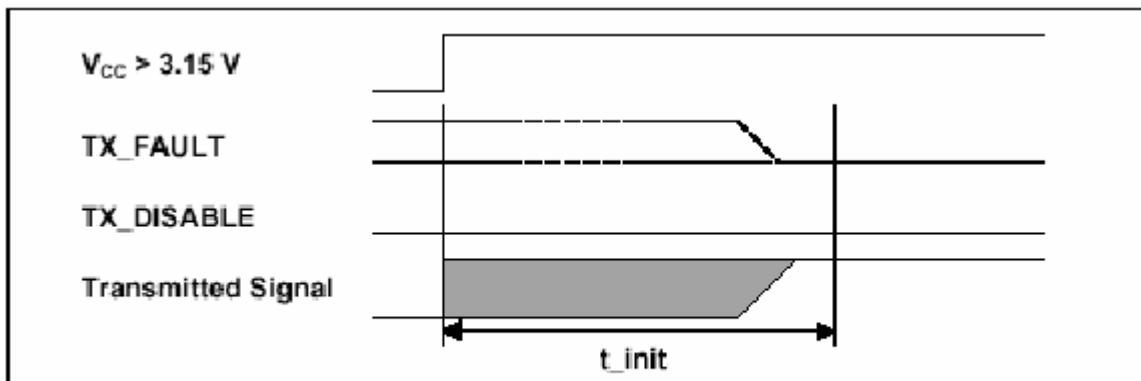

Figure 3. Power on initialization of SFP transceivers, Tx Disable negated

The power on initialization timing for a SFP transceiver with TX\_DISABLE asserted is shown in Figure 4.

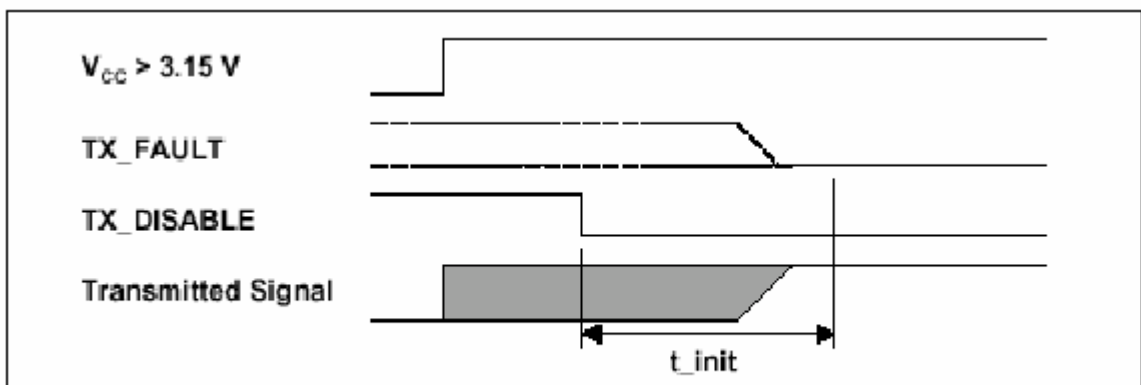

Figure 4. Power on initialization of SFP, Tx Diabile asserted

An example of initialization during hot plugging is provided in Figure 5.

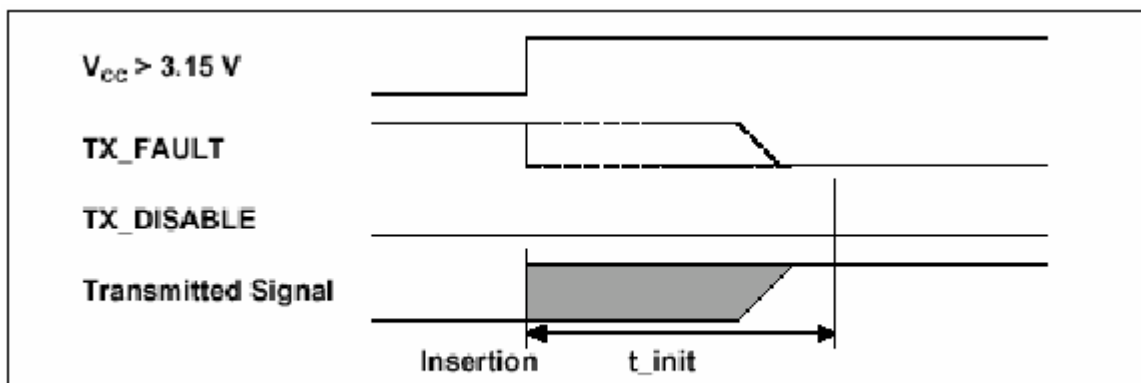

Figure 5. Example of initialization during hot plugging, Tx Disable negated

The timing requirements for the management of optical outputs from the SFP transceiver using the TX\_DISABLE signal are shown in Figure 6.

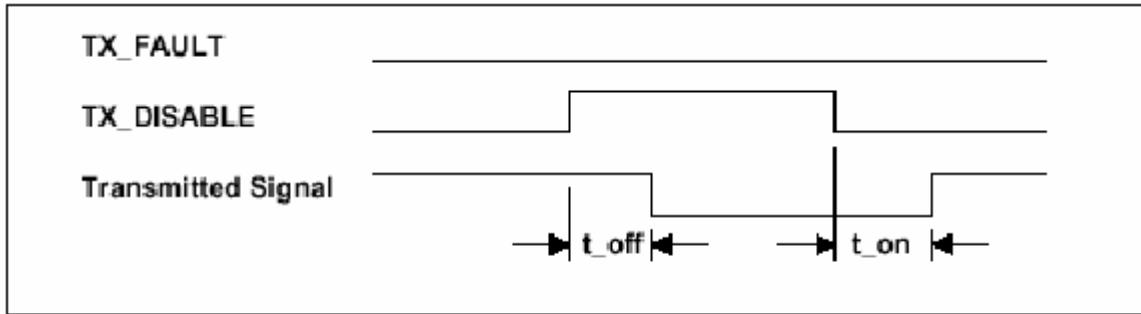

Figure 6. SFP Tx Disable timing during normal operation

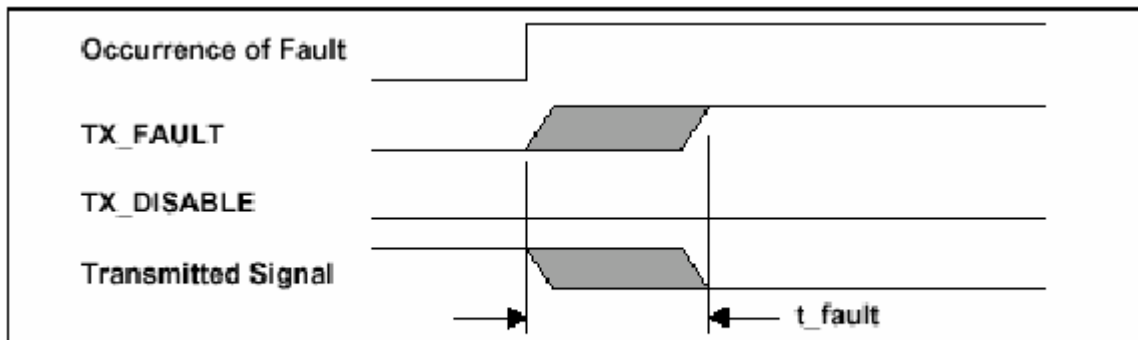

Figure 7. Detection of transmitter safety fault condition

The timing for successful recovery from a transient safety fault condition is shown in Figure 8.

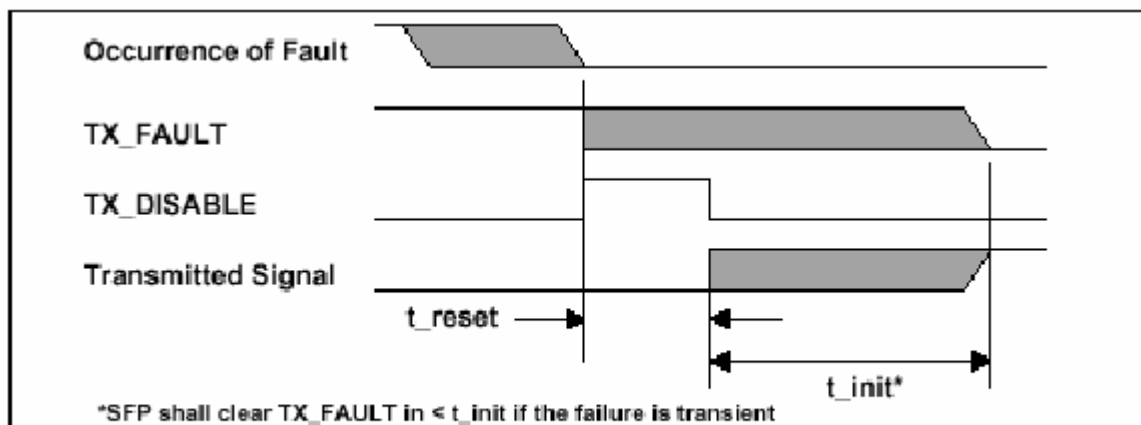

Figure 8. Successful recovery from transient safety fault condition

An example of an unsuccessful recovery, where the fault condition was not transient, is shown in Figure 9.

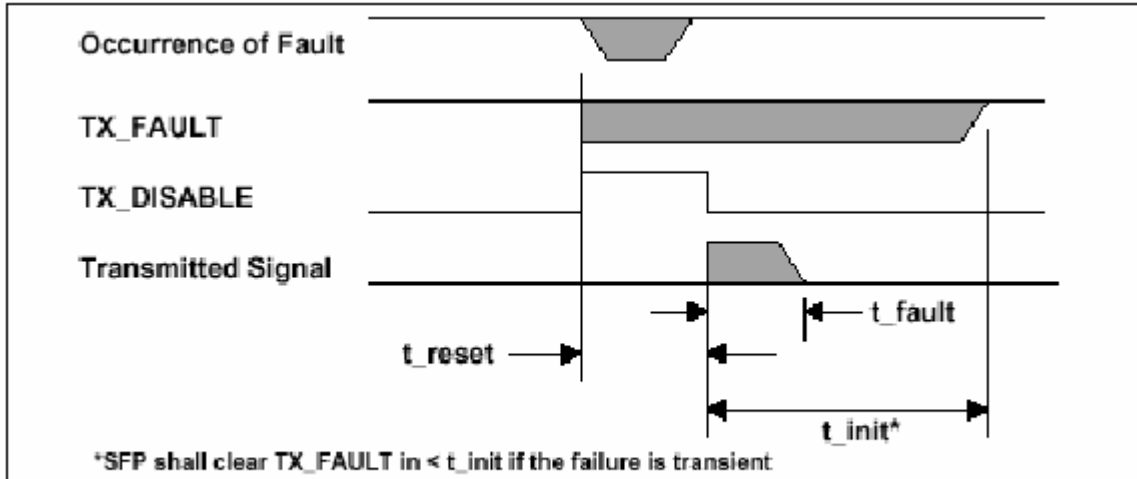

Figure 9. Unsuccessful recovery from safety fault condition

The timing of the LOS function is specified in Figure 10.

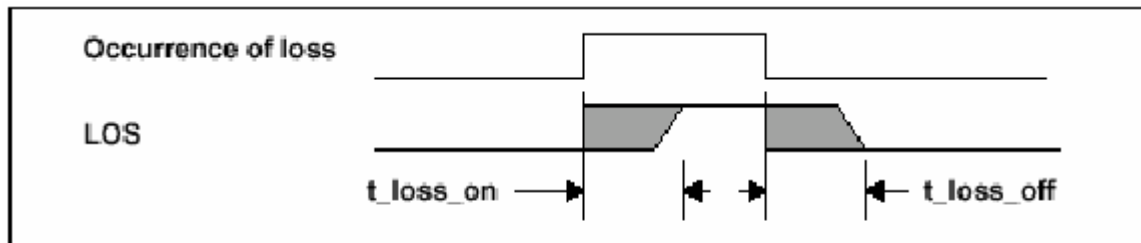

Figure 10. Timing of LOS detection

## Serial ID

Data Address	Length	Name of Field	Description
<b>BASE ID FIELDS</b>			
0	1	Identifier	03h=SFP
1	1	Ext. Identifier	04h=All SFP modules indicating serial ID module definition
2	1	Connector	07h=LC
3-10	8	Transceiver	SONET code - Reserved Gigabit Ethernet code - Reserved FC(Fibre Channel) link length – Intermediated distance FC transmitter technology - SN FC transmission media – Multi-mode 50/62.5 um FC speed – 100/200 Mbytes/Sec
11	1	Encoding	01h=8B10B
12	1	BR, Nominal	19h=100MHz*25=2.5GHz
13	1	Reserved	
14	1	9μ, distance	
15	1	9μ, distance	
16	1	50μ, distance	19h=25*10m=250m
17	1	62.5μ, distance	0Ch=12*10m=120m
18	1	CU, distance	
19	1	Reserved	
20-35	16	Vendor name	OPTICIS
36	1	Reserved	
37-39	3	Vendor OUI	
40-55	16	Vendor PN	M3-250-PAT (in case of 2.5Gbps AC coupled type SFP)
56-59	4	Vendor rev	
60-62	3	Reserved	
63	1	Check sum	Least significant byte of sum of data in addresses 0-62
<b>EXTENDED ID FIELDS</b>			
64-65	2	Options	00h & 1Ah = LOS, Tx_Fault, Tx_Disable all supported
66	1	BR, max	Unspecified
67	1	BR, min	Unspecified
68-83	16	Vendor SN	Unspecified
84-91	8	Date code	Date and lot number
92-94	3	Reserved	
95	1	Check sum	Least significant byte of sum of data in addresses 64-94
<b>VENDOR SPECIFIC ID FIELDS</b>			
96-127	32	Readable	

## Mechanical Dimensions

Dimensions are in millimeters (inches).

Tolerances : x.xx ± 0.025mm

x.x ± 0.05mm, unless otherwise specified

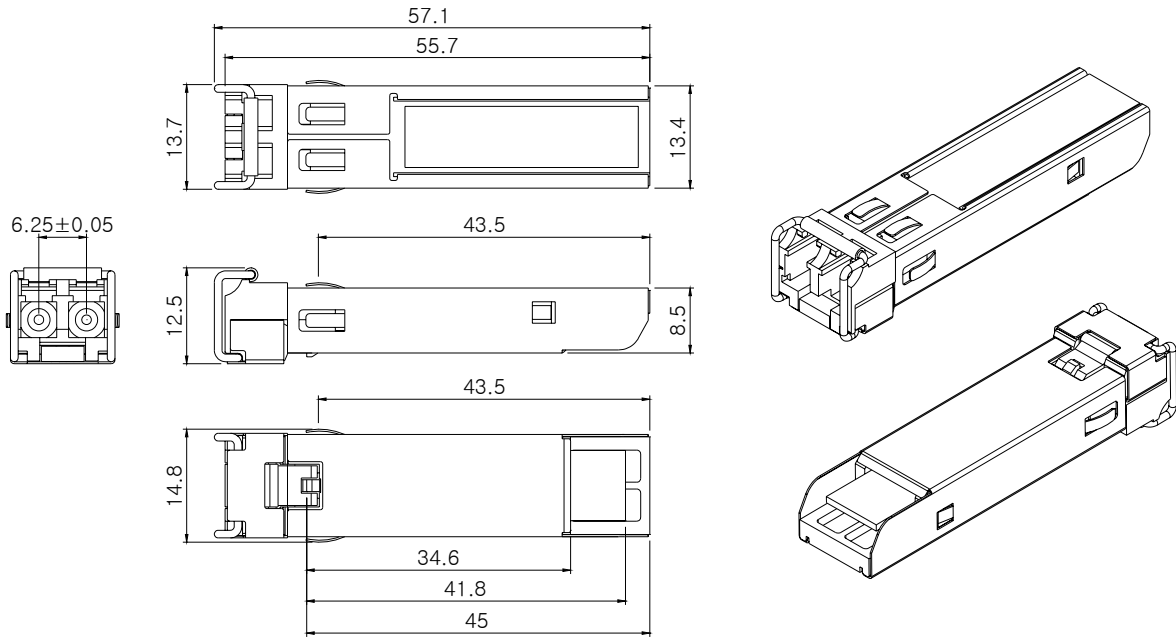

\* Cage : SPT-R020-CT,CL ( DDK Electronics )

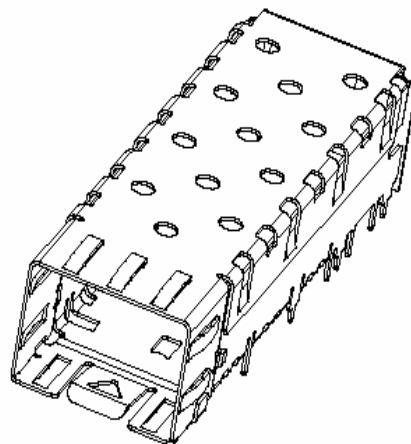

## **Ordering Information**

### **M3-XXX-ABC**

XXX: 106 and 125 stand for 1.0615Gbit data rate for Fibre Channel and 1.25Gbit data rate for Gbit Ethernet, respectively. 212 and 250 stand for 2.125Gbit data rate for Fibre Channel and 2.5Gbit data rate for Gbit Ethernet, respectively.

A: Connector style, that is, S for SC, L for LC, and P for Pluggable

B: Receiver termination, that is, A for AC coupling and D for DC coupling

C: LOS level, that is, T for TTL