



*User's Manual*  
*(For M1-100A)*

## Manual Contents

---

Manual Contents	1-0
Welcome!, Product Description	1-1
System Requirements for Setup	1-2
Installation	1-3
Troubleshooting, Maintenance, Technical Support	1-5
Product Specifications	1-6
Warranty Information	1-7
Regulatory Statements	1-8

### Pictorials

Figure 1 – Express All-Fiber DVI cable system	1-1
Figure 2 – Self EDID button	1-3
Figure 3 – The Tx or Rx Module of M1-100A Cable	1-4

## Welcome!

Congratulations on your purchase of the **Express All-Fiber DVI M1-100A** (Digital Visual Interface) Cable. This manual contains information that will assist you in installing and operating the product.

### Product Description

The M1-100A optical DVI cable transmits four (4) optical data, Red, Green, Blue and clock and can be extended up to 500 meters (1,640ft) over an all 4 multi-mode fibers cable at WUXGA (1920x1200) at 60Hz vertical refresh rate. The EDID (Extended Display Identification Data) in a display can be programmed by just plugging once transmitter to the display. This **self EDID programming** feature makes the installation of M1-100A more easy and flexible at any variable resolution display systems. For your convenience, UXGA VESA EDID would have been done before shipment as a default.

### Shipping Group

- M1-100A Optical DVI Cable:** One (1) unit
- +5V AC/DC power adaptor:** Two (2) units
- User's Manual**

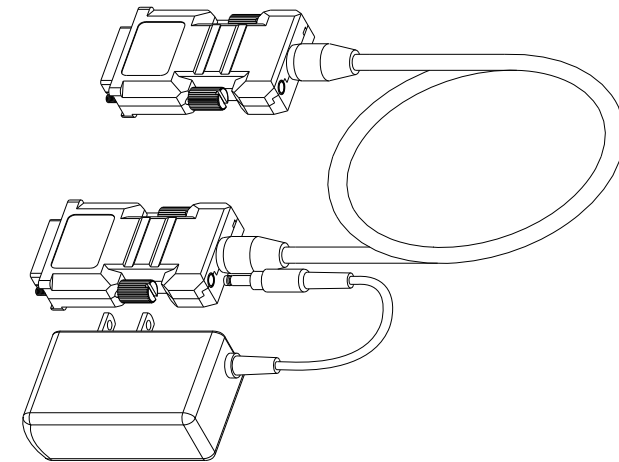

**Figure 1 – Express All-Fiber DVI Cable System**

## System Requirements for Setup

### □ Hardware requirements

- You have to have a DVI graphic controller or card having a DVI port in your PC, SUN or Mac systems. It should support the maximum graphic resolution feature of displays to be connected.
- No special requirements memory size, CPU speed and chipsets, if you've already properly installed your DVI graphic controllers or cards.

### □ Software requirements

- No special restrictions, if you've already properly installed your DVI graphic controller in your OS.

### □ AC/DC Power Adapter Technical Advisory

The M1-100A is designed for its Tx module to use +5V internal power supplied through a DVI pin (#14) from the graphic card. For ease of use or safety, the Tx module has a power auto-switching circuit to protect from plugging the external power while powering through DVI pin from the graphic cards.

However, its Rx module requires one external +5V AC/DC power adaptor to drive.

## Installation

**Important: Please use the installation procedure below. Improper or no operation may result if the start-up sequence is not correctly followed.**

### Step 1

Plug the 5V power adapter to the power jack of the transmitter, and connect the adapter to the mains electricity. Ensure the blue LED ON.

### Step 2 (Self EDID)

- a) **Push the Self EDID button of the powered transmitter with a narrow pin.** After twice blinking of Blue LED, it will be turned off.
- b) **Connect the powered transmitter to display while turned on, not to the PC.** The LED blinking indicates reading the EDID. LED OFF after blinking notices programming done.
- c) Disconnect the transmitter from the display. Then LED ON again.

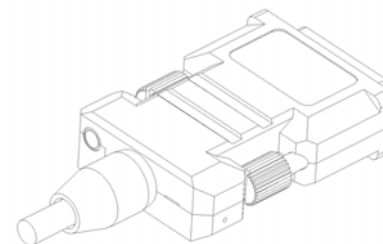

Figure 2 –Self EDID button

**Note:** If you want to change the display, please do again the step 2. **The default EDID in factory ship-out is programmed in the VESA standard of UXGA (1600x1200) 60Hz.**

### Step 3

Connect 5V power adapter to the receiver. Try the transmitter to connect to the PC and ensure if its blue LED lights ON. If not, plug 5V power adapter to the transmitter, which means your graphic card doesn't supply sufficient DC power through DVI connector.

**Note:** If you use laptop or Desktop PC with PCI Express graphic card, we recommend using +5V power adapter for the transmitter.

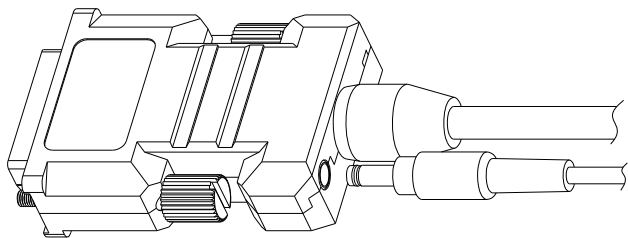

Figure 3 – The Tx or Rx Module of M1-100A Cable

**Note:** Recommend **NOT** to use any intermediate cable or adapter between the Tx and the PC or the Rx and the display.

#### Step 4

Power on the PC and display.

**Note:** If you want to change a display with different specification, please do self EDID programming again by following the **Step2**.

#### Step 5

Go to Display Properties in Windows systems and click the tap of Settings. Then you can set the right display resolution to meet your display. Once you set the right resolution, you could see displaying the initial screen at the same resolution as just before you powered on.

**Note:** If you cannot see the initial screen of the OS system and have skipped the **Step 1** and **Step 2**, you have to follow the **Step 1** and **Step 2** instructions.

#### Step 6

You can see processing of the system boot-up.

## Troubleshooting

### ***The display displays only black screen.***

Ensure that all AC and DC plugs and jacks used by external power supplies (both Opticis and others) are firmly connected. Ensure that power bars are live.

Ensure that Self EDID programming is performed according to installation guide Step 2. Ensure that the DVI ports are firmly plugged in to the PC and display. Ensure that the transmitter and receiver plug correctly to the PC and display, respectively.

Check if the PC and display are powered on and properly booted.

Reset the system by de-plugging and re-plugging the Tx DVI port or Rx DVI port, or by de-plugging and re-plugging the power cord plugs of transmitter and receiver.

Re-boot up the system while connecting the optical DVI cable system.

### ***Screen is distorted or displays noises.***

Check if the graphic resolution is properly set. Go to the display properties of Windows and tap the settings. Ensure that the resolution sets less than WUXGA (1,920x1,200) at 60Hz refresh ratio.

Reset the system. Disconnect and reconnect the optical DVI cables or DC power adapters.

## Maintenance

No special maintenance is required for the optical DVI cables and power supplies. Ensure that the cables and power modules are stored or used in a benign environment free from liquid or dirt contamination.

There are no user serviceable parts. Refer all service and repair issues to Opticis.

## Technical Support and Service

For commercial or general product support, contact your reseller. For technical service, contact Opticis by email [techsupp@opticis.com](mailto:techsupp@opticis.com) or visit its website at [www.opticis.com](http://www.opticis.com)

## Product Specifications

### M1-100A Express All-Fiber DVI Cable

- **Compliance with DVI standard:** support DVI1.0 and DDC2B, fully implemented by fiber-optic communication.
- **Extension limit:** 500m (1,650feet) for WUXGA (1,920x1,200) at 60 Hz refresh rate.
- **Graphic Transmission Bandwidth:** support WUXGA at 60Hz, or 1.65Gbps bandwidth per graphic channel.
- **Pure 4 strands Fiber-optic Cable: UL certified** Riser Jacket of Flame retardant PVC employing 4 strands.
- **Tensile load: 600N** (cable only)
  - Minimum bend radius: 12.0cm
  - Outer diameter of cable: 5.5cm
- **Mechanical specifications of Tx and Rx modules**
  - **Dimensions:** 39mm / 15.4mm / 52.3mm (W/H/D)
  - **Clamping strength to cable:** 14kg (Installing)<sub>f</sub>
- **Environmental Specifications**
  - Operating temperature: 0°C to 50°C
  - Storage temperature: - 30°C to 70°C
  - Humidity: 10% to 85%

### AC/DC Power Adapter

- **Power Input:** AC 100-240V, 50/60Hz 0.1A
- **Power Output:** +5 V, SMPS DC-power Adapter
- **Cord DC Jack:** Core is 5 V and outer is GND.

## Warranty Information

### 1 (One) Year Warranty

Opticis warrants this optical DVI extension cable to be free from defects in workmanship and materials, under normal use and service, for a period of one (1) year from the date of purchase from Opticis or its authorized resellers.

If a product does not work as warranted during the applicable warranty period, Opticis shall, at its option and expense, repair the defective product or part, deliver to customer an equivalent product or part to replace the defective item, or refund to customer the purchase price paid for the defective product.

All products that are replaced will become the property of Opticis.

Replacement products may be new or reconditioned.

Any replaced or repaired product or part has a ninety (90) day warranty or the remainder of the initial warranty period, whichever is longer.

Opticis shall not be responsible for any software, firmware, information, or memory data of customer contained in, stored on, or integrated with any products returned to Opticis for repair under warranty or not.

### Warranty Limitation and Exclusion

Opticis shall have no further obligation under the foregoing limited warranty if the product has been damaged due to abuse, misuse, neglect, accident, unusual physical or electrical stress, unauthorized modifications, tampering, alterations, or service other than by Opticis or its authorized agents, causes other than from ordinary use or failure to properly use the Product in the application for which said Product is intended.

## FCC/CE Statement

This device complies with the limits for a Class B digital device, pursuant to part 15 and 2 of FCC Rules and EN 55022/55024/61000-3 for CE certification. These limits are designed to provide reasonable protection against harmful interference when the equipment is operated in a residential installation. Operation is subject to the following two conditions: (1) this device may not cause harmful interference, and (2) this device must accept any interference received, including interference that may cause undesired operation. This equipment generates, uses, and can radiate radio frequency energy and, if not installed and used in accordance with the instruction guide, may cause harmful interference to radio communications. However, there is no guarantee that interference will not occur in a particular installation. If this equipment does cause harmful interference to radio or television reception, which can be determined by turning the equipment off and on, the user is encouraged to try to correct the interference by one or more of the following measures:

- Re-orient or relocate the receiving antenna.
- Increase the separation between the equipment and the receiver.
- Connect the equipment into an outlet on a circuit different from that to which the receiver is connected.
- Consult a service representative for help.

Properly shielded and grounded cables and connectors must be used in order to comply with FCC/CE emission limits. Changes or modifications not expressly approved by the party responsible for compliance could void the user's authority to operate the equipment.

## CB Scheme & UL Statement

In addition, this device as a low-voltage device has been also certified by the CB scheme, complied with IEC 60950-1.

This device has completed a UL Commercial Inspection and Testing Services for the multimode 8 strands distribution cable complied with OFNR (UL). It is validated by the UL, E203488 OFN FT4 (CSA) LS Cable (Year of manufacturer). All components are verified under the conformity of UL94-V0 flammability.

## LASER Safety

This device has been certified in compliance with IEC60825-1/2 and identified as a Class 1 LASER Product. It has been designed to limit the Laser power output less than Class 1, even though disconnection or breaking of cables may happen.



## 1-8 Regulatory Statements

© 2009 Opticis Co., Ltd. All Rights Reserved  
Revision 2.2, Nov. 26, 2009

## Opticis Locations

### Headquarters

Opticis Co., Ltd.

#304, Byucksan Technopia, 434-6  
Sangdaewon-Dong, Chungwon-Ku,  
Sungnam City, Kyungki-Do, 462-716  
South Korea

Tel: +82 (31) 737-8033~8

Fax: +82 (31) 737-8079

[www.opticis.com](http://www.opticis.com)

### North American Office

Opticis USA LLC

649 Route 206  
Unit 9 Suite 307  
Hillsborough, NJ 08844

Tel: 908-837-9652

Fax: 908-837-9078

[cdkim@opticis.com](mailto:cdkim@opticis.com)

For order support, please contact your Distributor or Reseller.

For technical support, check with the Opticis web site [www.opticis.com](http://www.opticis.com) or contact [techsupp@opticis.com](mailto:techsupp@opticis.com)