



Optical DVI Daisy-chain Extender

*User's Manual
for the M5-2000 & 2001*



Manual Contents

Manual Contents	1-0
Welcome!, Product Description	1-1
System Requirements for Setup	1-2
Installation	1-3
Troubleshooting, Maintenance, Technical Support	1-5
Product Specifications	1-6
Warranty Information	1-7
Regulatory Statements	1-8

Pictorials

Figure 1 – Overall Optical DVI daisy chain system	1-1
Figure 2 – Connection of DVI cable and power adaptor in M5-2000	1-3
Figure 3 – Connection of DVI cables to displays and power adaptor in M5-2001	1-3
Figure 4 – Connection of duplex LC fiber cables	1-4
Figure 5 – Fiber Connection between two (2) M5-2001s	1-4

Welcome!

Congratulations on your purchase of the optical DVI daisy chain extender, consisting of a M5-2000, Optical DVI converter and multiple M5-2001, Optical DVI repeaters. This manual contains information that will assist you in installing and operating the product.

Product Description

The M5-2000 module converts DVI input into two-channel optical signals and transmits over multimode glass or fiber cables with duplex LC plugs to the M5-2001 module. Also, the M5-2001 module repeats to the next M5-2001 module and at the same time distributes into two DVI outputs. The combination of one (1) M5-2000 and multiple M5-2001 makes DVI daisy chain connection remotely placed at 500m (1,670ft) in maximum between modules. For the sake of right display on connected monitors, the factory offers programming EDID of a user's monitor to the EEPROM in the M5-2000.

Shipping Group of

M5-2000 Optical DVI converter

- **The converter box:** One (1) Converter Box.
- **AC/DC power adapter:** One (1) +12V/3A units (including AC cord).
- **User's Manual**

M5-2001 Optical DVI repeater

- **The repeater box:** One (1) Repeater Box.
- **AC/DC power adapter:** One (1) +12V/3A units (including AC cord).
- **User's Manual**

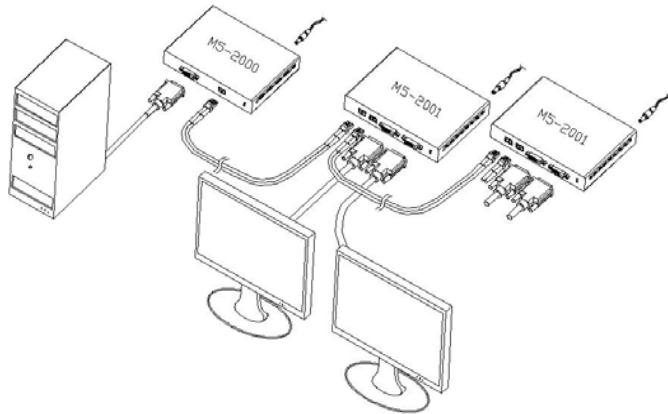

Figure 1 – Overall Optical DVI daisy-chain system

1-1 Welcome, Product Description

System Requirements for Setup

- **Hardware requirements**
 - You have a graphic controller card with a DVI port in your Windows/Mac (Mac is option), or SUN system. It should support the maximum graphic resolution feature of the display to be connected.
 - In case of using a computer, no special memory size, CPU speed and chipsets are required.
 - Step-by-step connection of multiple M5-2001s is strongly recommended prior to install all M5-2001 boxes in a time.
- **Software requirements**
 - No special needs, if the DVI graphic controller and display peripheral are operational with the platform's OS and application.
- **AC/DC Power Adapter Technical Advisory**

The power of M5-2000 and 2001 is designed to supply to each module of them by plugging to each of the power plugs.

1-2 System Requirements for Setup

Installation

Important: Please use the installation procedure below. Improper, or no operation may result if the start-up sequence is not correctly followed.

Step 1

Carefully unpack the contents of the shipping group. Before next step, ensure that your graphic card is set at no higher than SXGA (1,280x1,024) 60Hz in direct connection of copper DVI cables.

Step 2

With system power turned **off**, connect the M5-2000 converter box to the DVI receptacle of a computer or a video controller by a DVI copper cable. Plug the power adaptor in the shipping group and ensure its Power indicator lights on. The Link indicator will light on after the graphic cards power on. Recommend to power it after all connections are ready.

Notice: Longer cables over 2m could deteriorate the overall graphic quality.

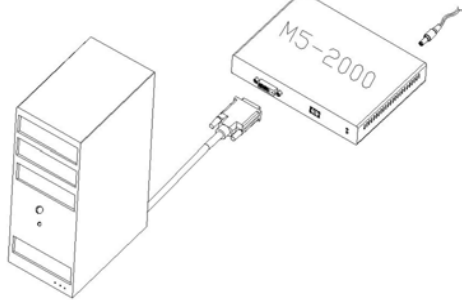

Figure 2 – Connection of DVI cable and power adaptor in M5-2000

Step 3

In the same way as above, connect the repeater box, M5-2001 with two (2) DVI copper cables into each of displays. Plug the power adaptor to the M5-2001 and ensure its Power indicator lights on.

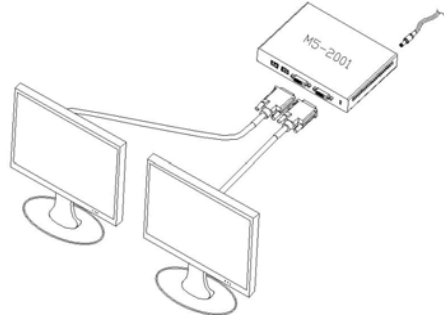

Figure 3 – Connection of DVI cables to displays and power adaptor in M5-2001

1-3 Installation

Step 4

Remove the module dust covers and connect a duplex LC fiber cable to LC receptacles of the M5-2000 converter and M5-2001 repeater, as shown in Fig. 4. Ensure plugging to the IN of two (2) duplex connectors in M5-2001. The OUT will be connected to the IN of the next M5-2001.

Notice: Please make sure that you should use multimode glass of fiber.

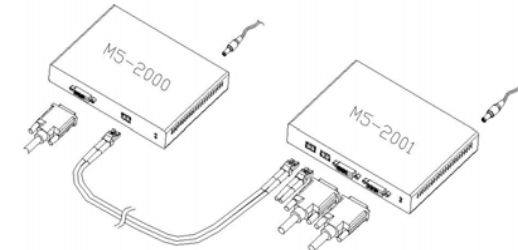

Figure 4 – Connection of duplex LC fiber cables

Notice: Please DO NOT look directly into the LC receptacles of M5-2000 and the OUT of M5-2001 boxes, while they are powered on, although they are regulated strictly enough to operate under the Laser Class I, classified by CDRH/FDA for eye safety.

Step 5

If you have another M5-2001, follow as **Step 3** and connect the duplex LC multimode fiber cables to the next M5-2001 as **Step 4**. The fiber connection is accomplished between the OUT of the prior M5-2001 and the IN of the next one. You have to repeat **Step 5** as many as you have.

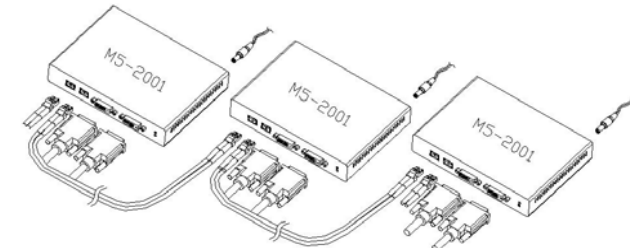

Figure 5 – Fiber Connection between two M5-2001s

Step 6

Power on the computer and displays or connected devices, if not ON. Ensure the Link indicators light on, presenting detecting signals and secure connection of LC duplex fiber cables and of the DVI cable in the M5-2000 box.

Tip 1: After initial installation as guided in the above, we recommend you to power On and Off while all connections are set and the converter and repeaters are powered On.

Tip 2: Avoid “hot plugging” the converter or repeater boxes as this is not recommended practice with live digital voltages.

1-4 Installation (continued)

Troubleshooting

The display displays only black screen.

- Check that all AC and DC plugs and jacks used by external power supplies (both Opticis and others) are firmly connected.
- Ensure that power bars are live.
- Ensure that the converter and repeater boxes plug correctly to the computer and display, respectively.
- Check if the computer and display are powered on and properly booted.
- Ensure your graphic card is set at not higher than SXGA (1,248x1,024) at 60Hz refresh ratio.
- Ensure the programmed EDID be compatible with that of the connected monitors.
- Reset the converter and each of repeaters by de-plugging and re-plugging the power adaptors.
- Re-boot up the system after reconnecting the optical system cable.

Screen is distorted or displays noises.

- Check if the graphic resolution is properly set. Go to the display properties and tap the settings. Ensure that the resolution sets less than SXGA (1,248x1,024) at 60Hz refresh ratio.
- Reset the converter and each of repeaters or the system.
- Power down, disconnect and reconnect the optical system cable or DC power adaptors, and power up.

Maintenance

No special maintenance is required for the optical system cables and power supplies. Ensure that the cables and power modules are stored or used in a benign environment free from liquid or dirt contamination.

There are no user serviceable parts. Refer all service and repair issues to Opticis or its authorized distributor.

Technical Support and Service

For commercial or general product support, contact your reseller. For technical service, contact Opticis by email techsupp@opticis.com or visit its website at www.opticis.com.

Product Specifications

M5-2000 and 2001 Optical DVI daisy chain Extender

- **Compliance with DVI standard:** supports DVI 1.0 of DDWG, using fiber-optic communication links.
- **Extension limit:** 500 m (1,670 feet) for SXGA (1,248x1,024) 24bit color at 60Hz refresh rate in ultimate operation.
- **Fiber-optic Connection:** The converter, M5-2000 and repeater boxes, M5-2001 have duplex LC receptacles connected to two 50 or 62.5/125µm or Multi Mode glass fibers cables.
- **Virtual DDC:** Offers the factory programming of EDID of user's monitors, considering all monitors to be connected be compatible with the programmed data.
- **Mechanical specifications of Uplink and Downlink boxes**
 - **Dimensions:** 180mm / 125mm / 30mm (W/H/D)
 - **Weight:** 800.0 ± 3.0 gram for M5-2000 and M52001.
- **Environmental Specifications**
 - Operating temperature: 0°C to 50°C
 - Storage temperature: - 20°C to 70°C

AC/DC Power Adapter

- **Power Input:** Universal AC 85-264V, 50/60Hz, AC power cord with power jack.
- **Power Output:** +12 V, 3.0 A SMPS DC-power Adapter
- **Cord DC Jack & length:** Core is 12 V and outer cylinder is GND. Length is 18.5 cm
- **AC Cord length:** 1.8m
- **Certification:** PSE, UL, cUL, FCC, CE, TUV-GS



Warranty Information

1 (One) Year Warranty

Opticis warrants this optical DVI daisy chain Extender to be free from defects in workmanship and materials, under normal use and service, for a period of one (1) year from the date of purchase from Opticis or its authorized resellers.

If a product does not work as warranted during the applicable warranty period, Opticis shall, at its option and expense, repair the defective product or part, deliver to customer an equivalent product or part to replace the defective item, or refund to customer the purchase price paid for the defective product.

All products that are replaced will become the property of Opticis.

Replacement products may be new or reconditioned.

Any replaced or repaired product or part has a ninety (90) day warranty or the remainder of the initial warranty period, whichever is longer.

Opticis shall not be responsible for any software, firmware, information, or memory data of customer contained in, stored on, or integrated with any products returned to Opticis for repair under warranty or not.

Warranty Limitation and Exclusion

Opticis shall have no further obligation under the foregoing limited warranty if the product has been damaged due to abuse, misuse, neglect, accident, unusual physical or electrical stress, unauthorized modifications, tampering, alterations, or service other than by Opticis or its authorized agents, causes other than from ordinary use or failure to properly use the product in the application for which said product is intended.

FCC/CE Statement for regulation of Electro-magnetic emission

This device complies with part 15 of FCC Rules. Operation is subject to the following two conditions: (1) this device may not cause harmful interference, and (2) this device must accept any interference received, including interference that may cause undesired operation. This equipment has been tested and found to comply with the limits for a Class B digital device, pursuant to part 15 and 2 of FCC Rules, EN 55022/55024/61000-3 for CE certification. These limits are designed to provide reasonable protection against harmful interference when the equipment is operated in a residential installation. This equipment generates, uses, and can radiate radio frequency energy and, if not installed and used in accordance with the instruction guide, may cause harmful interference to radio communications. However, there is no guarantee that interference will not occur in a particular installation. If this equipment does cause harmful interference to radio or television reception, which can be determined by turning the equipment off and on, the user is encouraged to try to correct the interference by one or more of the following measures:

- Re-orient or relocate the receiving antenna.
- Increase the separation between the equipment and the receiver.
- Connect the equipment into an outlet on a circuit different from that to which the receiver is connected.
- Consult a service representative for help.

Properly shielded and grounded cables and connectors must be used in order to comply with FCC/CE emission limits. Changes or modifications not expressly approved by the party responsible for compliance could void the user's authority to operate the equipment.

Certification for Safety

The extension system is certified pursuant to IEC60065 and its AC/DC power adapter is certified by UL1310, 1950, 60950 for North America, cUL or CSA for Canada, TUV-CE & GS for EU and PSE for Japan.

Certification of Eye Safety

This laser product is inside implemented by using 1310nm/1550nm Bi-di Transceivers, manufactured by Opticis Co., Ltd., which are all certified by CDRH/FDA referred in Accession Number 0210774 as classified in Laser Class1.

Opticis Locations

Opticis Co., Ltd.
#501 Byucksan Technopia
434-6 Sangdaewon-Dong, Chungwon-Ku
Sungnam City, Kyungki-Do
462-120, South Korea
Tel: +82 (31) 737-8033
Fax: +82 (31) 737-8079

Opticis North America Ltd.
330 Richmond street, Suite 100
Chatham, Ontario
Canada N7M 1P7
Tel: (519) 355-0819
Fax: (519) 355-0520

For order support, please contact your Distributor or Reseller.

For technical support, check with the Opticis web site www.opticis.com or contact techsupp@opticis.com